

# Series 13-22-MXQ $\varnothing 6, \varnothing 8, \varnothing 12, \varnothing 16, \varnothing 20, \varnothing 25$ Air Slide Table



## How to Order

**Clean series**  
**13** Vacuum suction type (Special treatment on guide)

**22** Vacuum suction type  
 Copper, fluorine and silicone-free + Low particle generation

**Port thread type**

Symbol	Type	Bore size
Nil	M thread	$\varnothing 6$ to $\varnothing 16$
	Rc	$\varnothing 20, \varnothing 25$
TN	NPT	$\varnothing 20, \varnothing 25$
TF	G	$\varnothing 20, \varnothing 25$

**Symmetric type**

Nil	Standard
L	Symmetric

**Bore size/Stroke (mm)**

	10, 20, 30, 40, 50
6	10, 20, 30, 40, 50
8	10, 20, 30, 40, 50, 75
12	10, 20, 30, 40, 50, 75, 100
16	10, 20, 30, 40, 50, 75, 100, 125
20	10, 20, 30, 40, 50, 75, 100, 125, 150
25	10, 20, 30, 40, 50, 75, 100, 125, 150

**Adjuster option**

Nil	Without adjuster
AS	Extension end rubber stopper
AT	Retraction end rubber stopper
A	Both ends rubber stopper
CS	Extension end metal stopper
CT	Retraction end metal stopper
C	Both ends metal stopper
ASCT	Extension end adjuster + Retraction end metal stopper
CSAT	Extension end metal stopper + Retraction end adjuster

**Number of auto switches**

Nil	2 pcs.
S	1 pc.
n	"n" pcs.

**Auto switch**

Nil	Without auto switch (Built-in magnet)
-----	---------------------------------------

\* For the applicable auto switch model, refer to the table below.

**Functional option**

Nil	Standard
P (Note)	Axial piping

Note) The combination of axial piping and both ends adjusters or retraction end adjuster is not available.

## Auto Switch Specifications (Refer to the WEB catalog for detailed specifications and auto switches not in the following table.)

Type	Special function	Electrical entry	Indicator light	Wiring (Output)	Load voltage		Auto switch model	Lead wire length (m) *				Applicable load		
					DC	AC		Electrical entry direction						
							In-line				0.5 (Nil)		1 (M)	3 (L)
Reed auto switch	—	Grommet	Yes	2-wire	24 V	12 V	100 V	A93	●	—	●	—	—	Relay, PLC
Solid state auto switch	—	Grommet	Yes	3-wire (NPN)	24 V	12 V	—	M9N	●	●	●	○	—	Relay, PLC
				2-wire				M9B	●	●	●	○	—	

\* Lead wire length symbols: 0.5 m ..... Nil (Example) M9N  
 1 m ..... M (Example) M9NM  
 3 m ..... L (Example) M9NL  
 5 m ..... Z (Example) M9NZ

PLC: Programmable Logic Controller

Refer to page 889 for the applicable auto switch list.

**Specifications**

<b>Bore size (mm)</b>	6	8	12	16	20	25
<b>Fluid</b>	Air					
<b>Action</b>	Double acting					
<b>Operating pressure</b>	0.15 to 0.7 MPa					
<b>Proof pressure</b>	1.05 MPa					
<b>Ambient and fluid temperature</b>	-10 to 60°C (No freezing)					
<b>Piston speed</b>	50 to 300 mm/s (Adjuster option/Metal stopper: 50 to 200 mm/s)					
<b>Cushion</b>	Rubber bumper (Standard, Adjuster option/Rubber stopper) None (Adjuster option/Metal stopper)					
<b>Lubrication</b>	Non-lube					
<b>Stroke length tolerance</b>	+1 0 mm					
<b>Grease</b>	13-: Fluorine grease 22-: Lithium soap based grease					
<b>Cleanliness class (ISO class)</b>	Without adjuster	13-/22-: Class 5				
	Rubber stopper	13-/22-: Class 6				
	Metal stopper	13-/22-: Class 6				

**Suction Flow Rate of Vacuum Suction Type (Reference values)**

Bore size	Suction flow rate L/min (ANR)
6, 8, 12	1
16	2
20	3
25	5

**Adjuster Option: Stroke Adjustment Range**

Rubber stopper	Extension end (AS)	Stroke adjustment range 0 to 5 mm
	Retraction end (AT)	
	Both ends (A)	
Metal stopper	Extension end (CS)	Stroke adjustment range 0 to 5 mm
	Retraction end (CT)	
	Both ends (C)	

**Proper Auto Switch Mounting Position (Detection at Stroke End)**



**Reed auto switch: D-A93**

Model	A	B Stroke										E Stroke										Auto switch operating range
		10	20	30	40	50	75	100	125	150	10	20	30	40	50	75	100	125	150			
13-/22-MXQ6(L)	6	5.5	5.5	5.5	13.5	13.5	—	—	—	—	1	1	1	9	9	—	—	—	4.5			
13-/22-MXQ8(L)	7.5	8	8	12	16	31	32	—	—	—	3.5	3.5	7.5	11.5	26.5	27.5	—	—	5			
13-/22-MXQ12(L)	11.5	24.5	14.5	14.5	21.5	21.5	40.5	40.5	—	—	20	10	10	17	17	36	36	—	6			
13-/22-MXQ16(L)	16.5	30.5	20.5	20.5	20.5	26.5	33.5	51.5	51.5	—	26	16	16	16	22	29	47	47	7			
13-/22-MXQ20(L)	19	43.5	33.5	23.5	33.5	31.5	39.5	71.5	74.5	77.5	39	29	19	29	27	35	67	70	8			
13-/22-MXQ25(L)	22	52.5	42.5	32.5	32.5	46.5	46.5	60.5	88.5	88.5	48	38	28	28	42	42	56	84	9			

**Solid state auto switch: D-M9B, D-M9N**

Model	A	B Stroke										E Stroke										Auto switch operating range
		10	20	30	40	50	75	100	125	150	10	20	30	40	50	75	100	125	150			
13-/22-MXQ6(L)	10	9.5	9.5	9.5	17.5	17.5	—	—	—	—	-0.5	-0.5	-0.5	7.5	7.5	—	—	—	1.5			
13-/22-MXQ8(L)	11.5	12	12	16	20	35	36	—	—	—	2	2	6	10	25	26	—	—	1.5			
13-/22-MXQ12(L)	15.5	28.5	18.5	18.5	25.5	25.5	44.5	44.5	—	—	18.5	8.5	8.5	15.5	15.5	34.5	34.5	—	2.5			
13-/22-MXQ16(L)	20.5	34.5	24.5	24.5	24.5	30.5	37.5	55.5	55.5	—	24.5	14.5	14.5	14.5	20.5	27.5	45.5	45.5	3			
13-/22-MXQ20(L)	23	47.5	37.5	27.5	37.5	35.5	43.5	75.5	78.5	81.5	37.5	27.5	17.5	27.5	25.5	33.5	65.5	68.5	3			
13-/22-MXQ25(L)	27	56.5	46.5	36.5	36.5	50.5	50.5	64.5	92.5	92.5	46.5	36.5	26.5	26.5	40.5	40.5	54.5	82.5	3			



**Dimensions:** <sup>13-</sup><sub>22-</sub>MXQ6

Axial piping (ø6): <sup>13-</sup><sub>22-</sub>MXQ6-□□P

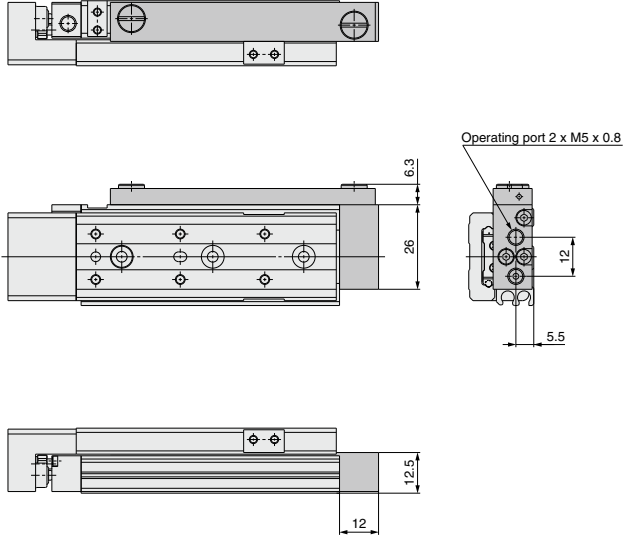

\* Other dimensions are the same as basic type.

Directional Control Valves

Air Cylinders

Rotary Actuators

Air Grippers

Air Preparation Equipment

Modular F. R.

Pressure Control Equipment

Fittings & Tubing

Flow Control Equipment

Pressure Switches/ Pressure Sensors

**Dimensions: 13-22-MXQ6L / Symmetric Type**

**Basic**

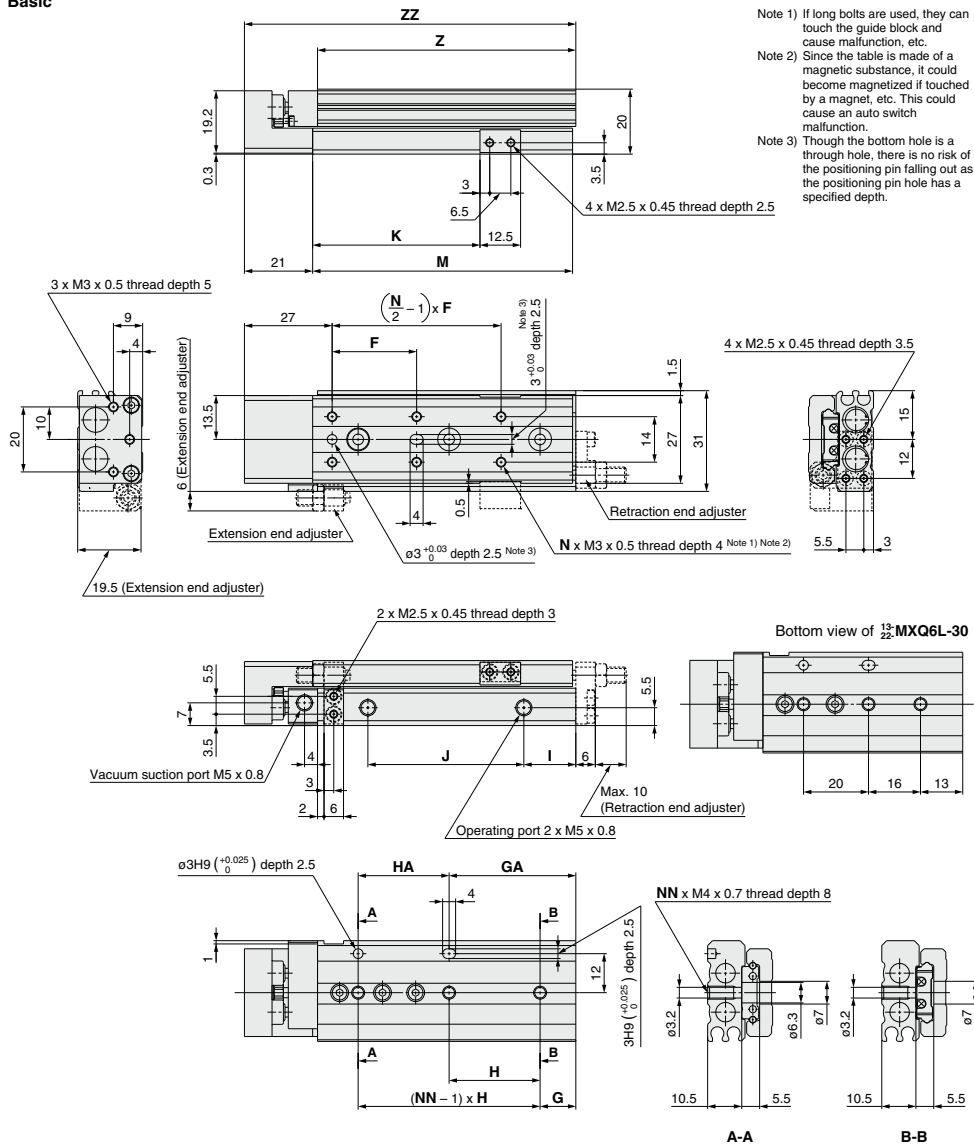

Note 1) If long bolts are used, they can touch the guide block and cause malfunction, etc.  
 Note 2) Since the table is made of a magnetic substance, it could become magnetized if touched by a magnet, etc. This could cause an auto switch malfunction.  
 Note 3) Though the bottom hole is a through hole, there is no risk of the positioning pin falling out as the positioning pin hole has a specified depth.

Model	F	N	G	H	NN	GA	HA	I	J	K	M	Z	ZZ
13-/22-MXQ6L-10	22	4	6	23	2	13	16	9	17	21.5	42	41.5	64
13-/22-MXQ6L-20	25	4	13	26	2	13	26	9	27	31.5	52	51.5	74
13-/22-MXQ6L-30	21	6	(Note)	(Note)	3	29	20	9	37	41.5	62	61.5	84
13-/22-MXQ6L-40	26	6	11	28	3	39	28	16	48	51.5	80	79.5	102
13-/22-MXQ6L-50	27	6	21	28	3	49	28	9	65	61.5	90	89.5	112

(mm)  
 Note) Refer to the bottom view of 13-22-MXQ6-30.

**Dimensions: <sup>13-</sup>/<sub>22-</sub>MXQ6L / Symmetric Type**

Axial piping (ø6): <sup>13-</sup>/<sub>22-</sub>MXQ6L-□□P

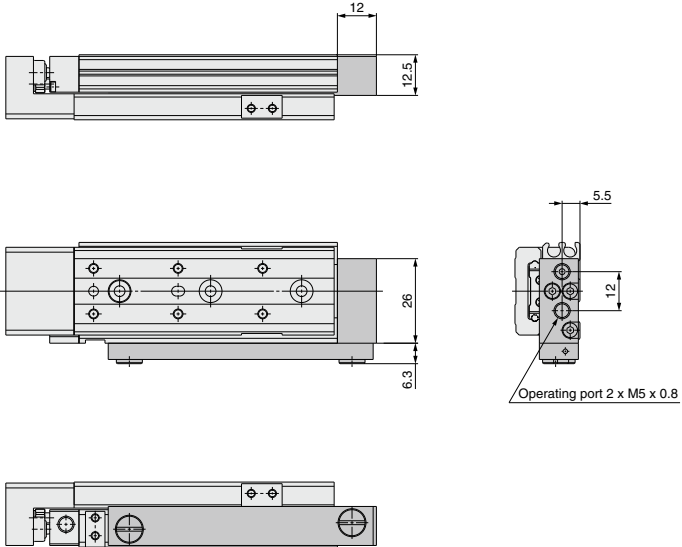

\* Other dimensions are the same as basic type.

Directional  
Control Valves

Air Cylinders

Rotary Actuators

Air Grippers

Air Preparation  
Equipment

Modular F. R.

Pressure Control  
Equipment

Fittings & Tubing

Flow Control  
Equipment

Pressure Switches/  
Pressure Sensors

**Dimensions: 13-22-MXQ8**

**Basic**

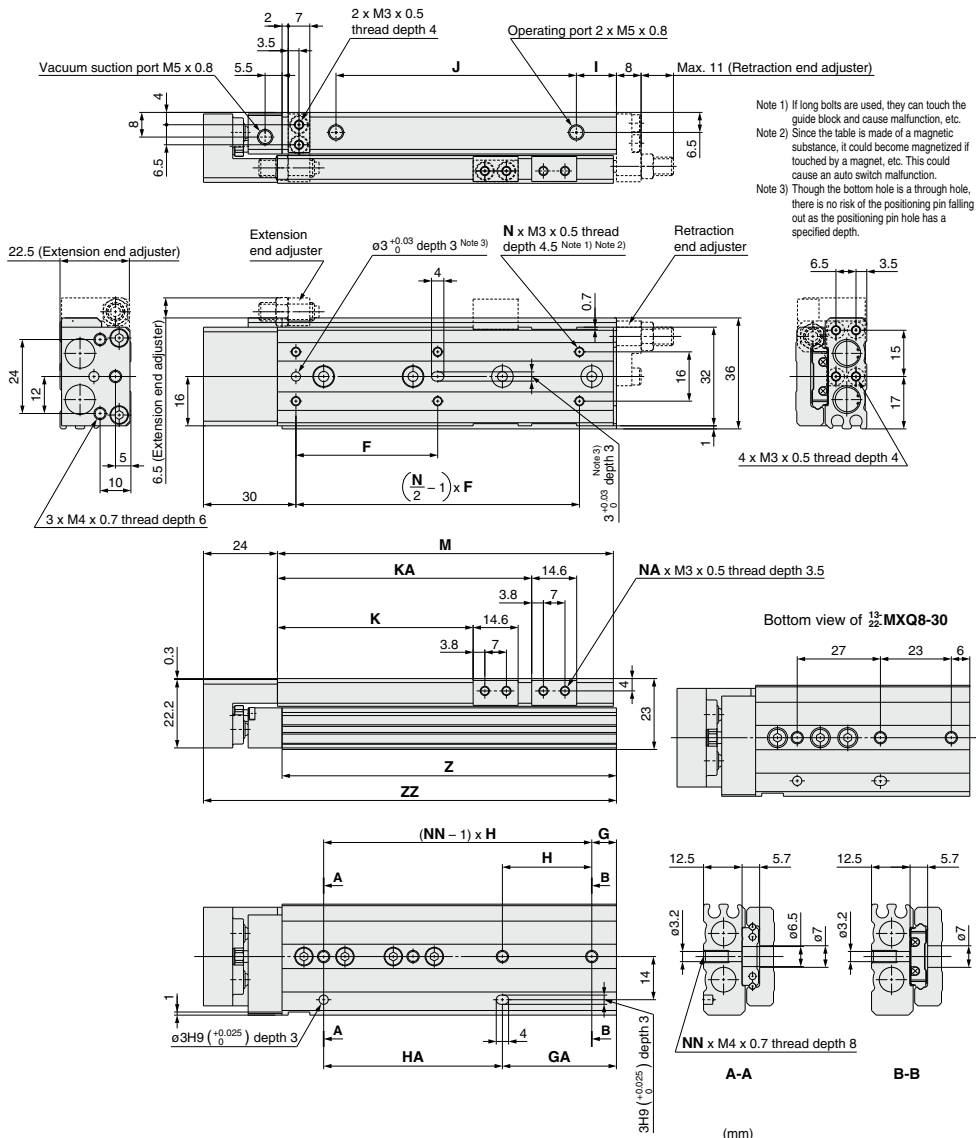

Model	F	N	G	H	NN	GA	HA	I	J	K	KA	NA	M	Z	ZZ
13-22-MXQ8-10	25	4	7	25	2	13	19	11	17	23.5	—	4	46	45.5	71
13-22-MXQ8-20	25	4	14	28	2	14	28	10	28	33.5	—	4	56	55.5	81
13-22-MXQ8-30	26	6	(Note)	(Note)	3	29	27	12	40	43.5	—	4	70	69.5	95
13-22-MXQ8-40	32	6	8	31	3	39	31	14	52	53.5	—	4	84	83.5	109
13-22-MXQ8-50	46	6	8	29	4	37	58	13	78	63.5	82.5	8	109	108.5	134
13-22-MXQ8-75	50	6	31	30	4	61	60	12	105	88.5	112.5	8	135	134.5	160

Note) Refer to the bottom view of 13-22-MXQ8-30.

**Dimensions:** <sup>13-</sup><sub>22-</sub>MXQ8

Axial piping (ø8): <sup>13-</sup><sub>22-</sub>MXQ8-□□P

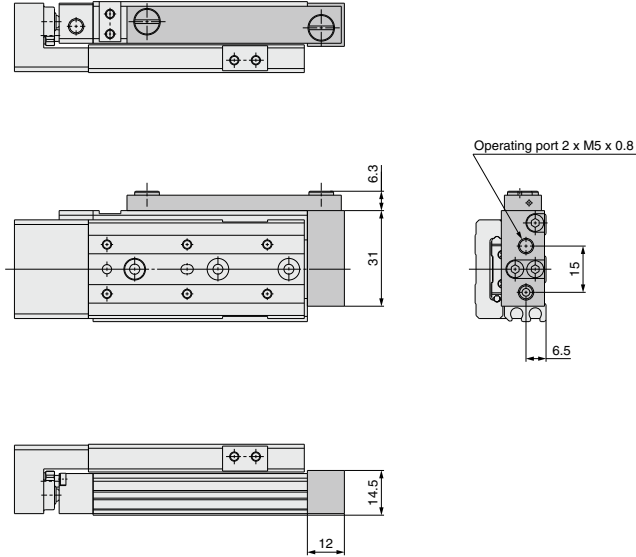

\* Other dimensions are the same as basic type.

Directional Control Valves

Air Cylinders

Rotary Actuators

Air Grippers

Air Preparation Equipment

Modular F. R.

Pressure Control Equipment

Fittings & Tubing

Flow Control Equipment

Pressure Switches/ Pressure Sensors





**Dimensions: <sup>13-</sup><sub>22-</sub>MXQ8L / Symmetric Type**

Axial piping (ø8): <sup>13-</sup><sub>22-</sub>MXQ8L-□□P

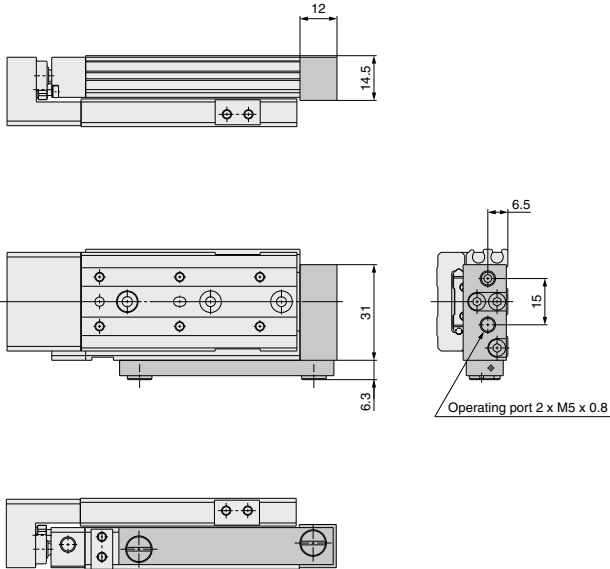

\* Other dimensions are the same as basic type.

Directional Control Valves

Air Cylinders

Rotary Actuators

Air Grippers

Air Preparation Equipment

Modular F. R.

Pressure Control Equipment

Fittings & Tubing

Flow Control Equipment

Pressure Switches/ Pressure Sensors

Dimensions: **13-22-MXQ12**

Basic

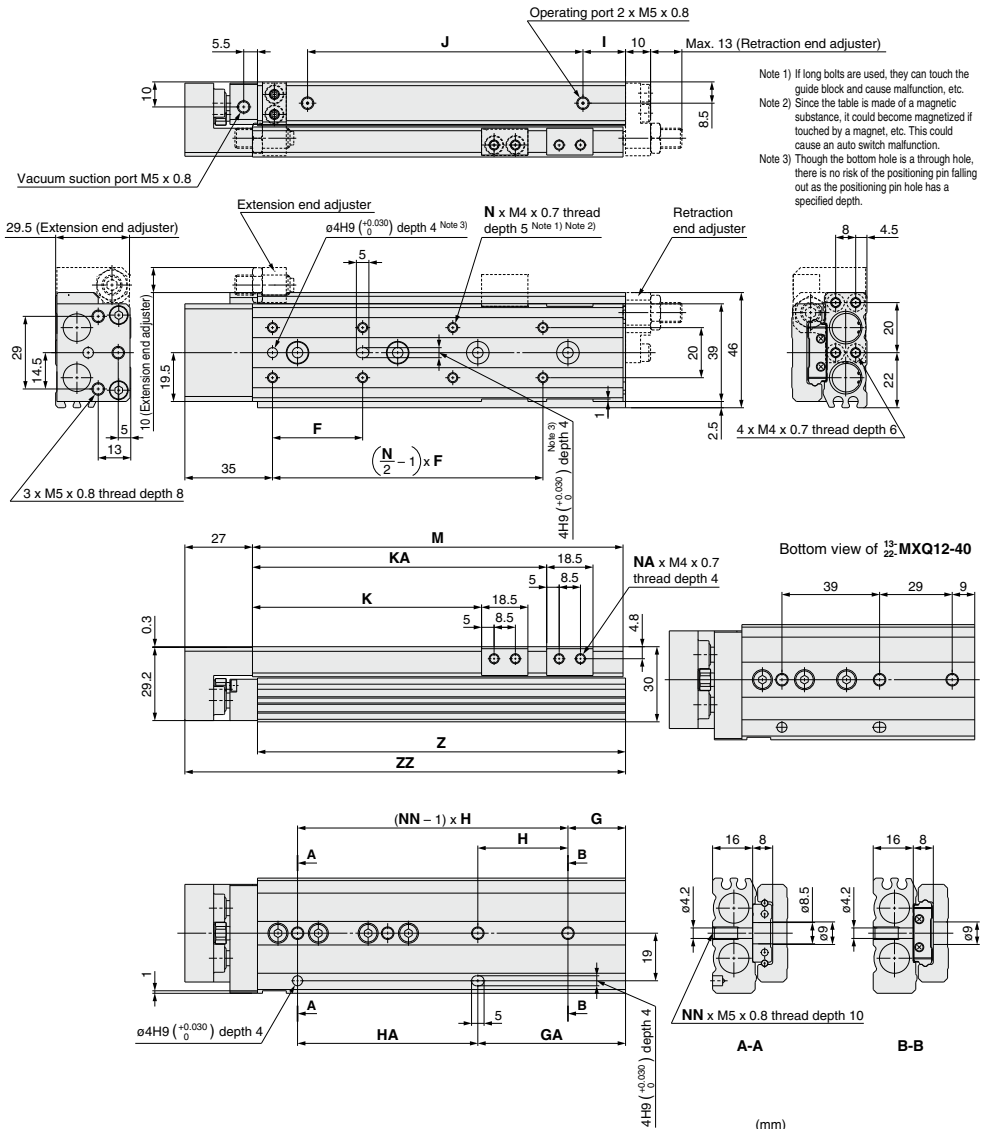

- Note 1) If long bolts are used, they can touch the guide block and cause malfunction, etc.
- Note 2) Since the table is made of a magnetic substance, it could become magnetized if touched by a magnet, etc. This could cause an auto switch malfunction.
- Note 3) Though the bottom hole is a through hole, there is no risk of the positioning pin falling out as the positioning pin hole has a specified depth.

Model	F	N	G	H	NN	GA	HA	I	J	K	KA	NA	M	Z	ZZ
13-22-MXQ12- 10	28	4	18	32	2	18	32	12	34	26.5	—	4	67	66	95
13-22-MXQ12- 20	28	4	18	32	2	18	32	12	34	36.5	—	4	67	66	95
13-22-MXQ12- 30	38	4	20	40	2	20	40	14	42	46.5	—	4	77	76	105
13-22-MXQ12- 40	34	6	$\frac{N(90)}{2}$	$\frac{N(90)}{2}$	3	38	39	15	58	56.5	—	4	94	93	122
13-22-MXQ12- 50	34	6	9	39	3	48	39	13	70	66.5	—	4	104	103	132
13-22-MXQ12- 75	36	8	23	36	4	59	72	17	110	91.5	117.5	8	148	147	176
13-22-MXQ12-100	36	10	12	36	5	84	72	17	135	116.5	142.5	8	173	172	201

Note) Refer to the bottom view of 13-22-MXQ12-40.

**Dimensions:** <sup>13-</sup><sub>22-</sub>MXQ12

Axial piping (ø12): <sup>13-</sup><sub>22-</sub>MXQ12-□□P

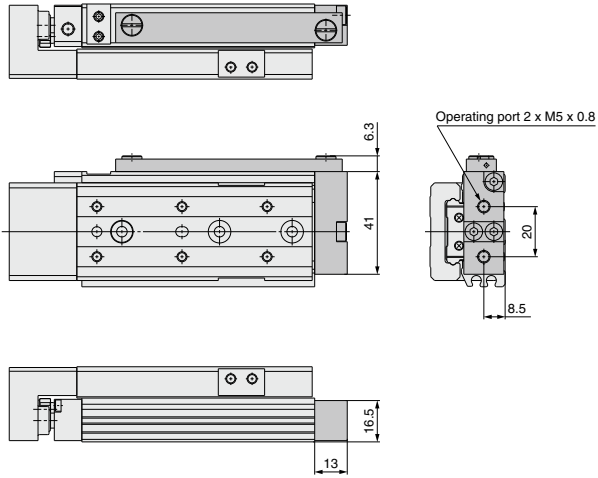

\* Other dimensions are the same as basic type.

Directional Control Valves

Air Cylinders

Rotary Actuators

Air Grippers

Air Preparation Equipment

Modular F. R.

Pressure Control Equipment

Fittings & Tubing

Flow Control Equipment

Pressure Switches/ Pressure Sensors



**Dimensions: 13-22-MXQ12L / Symmetric Type**

Axial piping (ø12): 13-22-MXQ12L-□□P

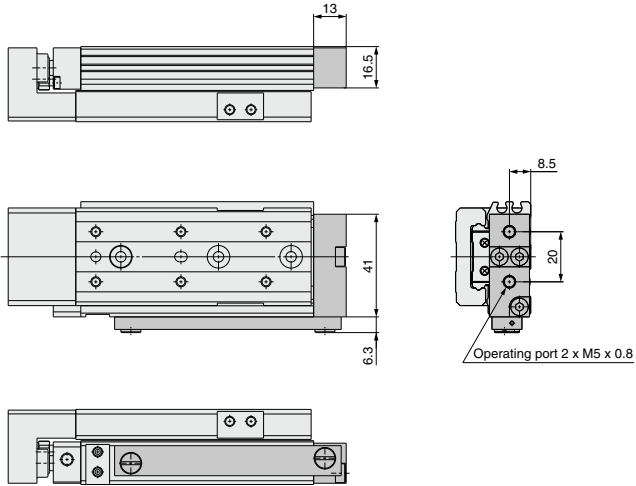

\* Other dimensions are the same as basic type.

Directional Control Valves

Air Cylinders

Rotary Actuators

Air Grippers

Air Preparation Equipment

Modular F. R.

Pressure Control Equipment

Fittings & Tubing

Flow Control Equipment

Pressure Switches/ Pressure Sensors

**Dimensions: 13-22-MXQ16**

**Basic**

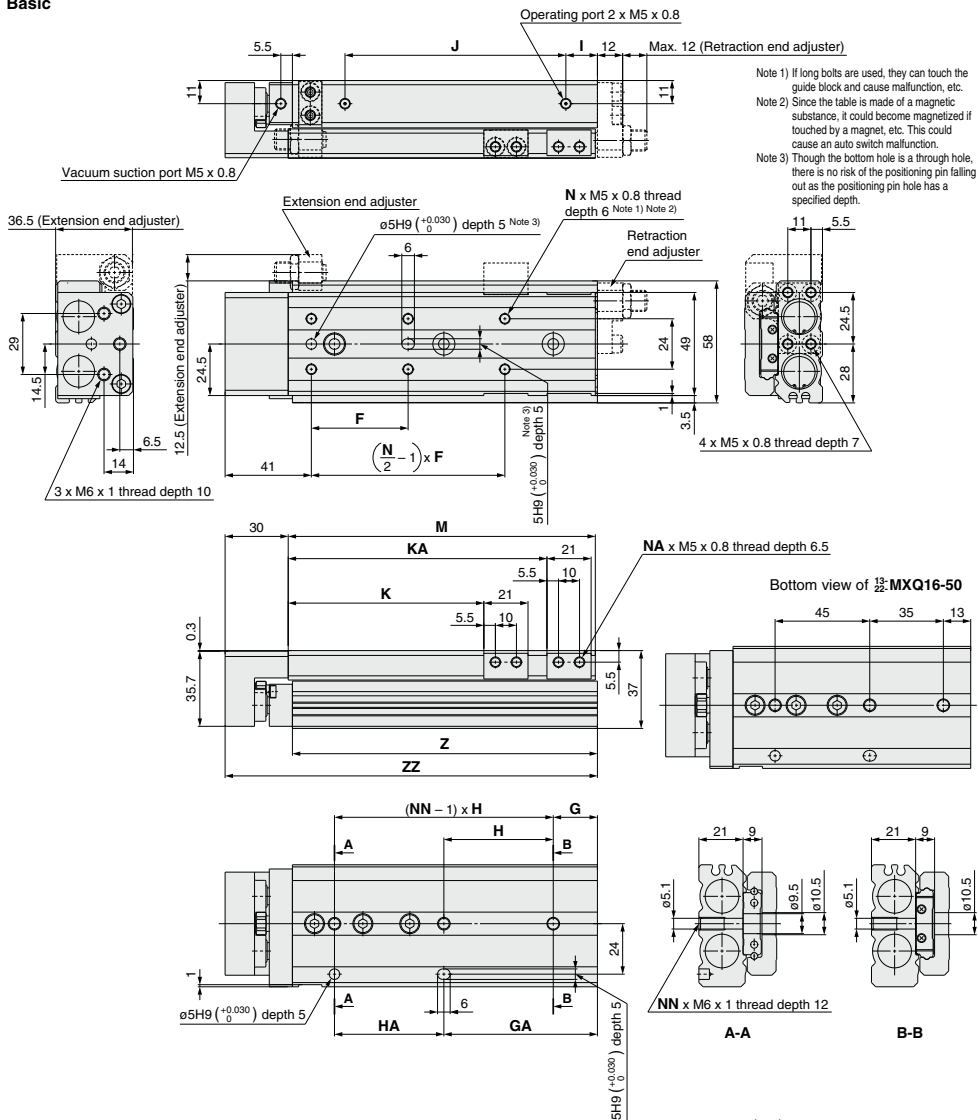

Note 1) If long bolts are used, they can touch the guide block and cause malfunction, etc.  
 Note 2) Since the table is made of a magnetic substance, it could become magnetized if touched by a magnet, etc. This could cause an auto switch malfunction.  
 Note 3) Though the bottom hole is a through hole, there is no risk of the positioning pin falling out as the positioning pin hole has a specified depth.

Model	F	N	G	H	NN	GA	HA	I	J	K	KA	NA	M	Z	ZZ
13-22-MXQ16- 10	38	4	18	39	2	18	39	12	40	28	—	4	78	77	109
13-22-MXQ16- 20	38	4	18	39	2	18	39	12	40	38	—	4	78	77	109
13-22-MXQ16- 30	48	4	19	48	2	19	48	12	50	48	—	4	88	87	119
13-22-MXQ16- 40	58	4	19	58	2	19	58	12	60	58	—	4	98	97	129
13-22-MXQ16- 50	40	6	<small>Note 3)</small>	<small>Note 3)</small>	3	48	45	20	68	68	91	8	114	113	145
13-22-MXQ16- 75	46	6	21	52	3	73	52	15	105	93	123	8	146	145	177
13-22-MXQ16-100	44	8	36	44	4	80	88	18	145	118	166	8	189	188	220
13-22-MXQ16-125	44	10	17	44	5	105	88	23	165	143	191	8	214	213	245

Note) Refer to the bottom view of 13-22-MXQ16-50.

**Dimensions:** <sup>13-</sup><sub>22-</sub>**MXQ16**

Axial piping (ø16): <sup>13-</sup><sub>22-</sub>**MXQ16-□□P**

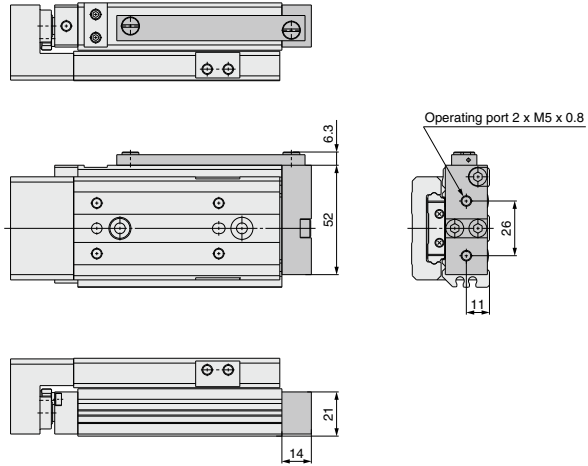

\* Other dimensions are the same as basic type.

Directional Control Valves

Air Cylinders

Rotary Actuators

Air Grippers

Air Preparation Equipment

Modular F. R.

Pressure Control Equipment

Fittings & Tubing

Flow Control Equipment

Pressure Switches/ Pressure Sensors



**Dimensions: 13-22-MXQ16L / Symmetric Type**

**Basic**

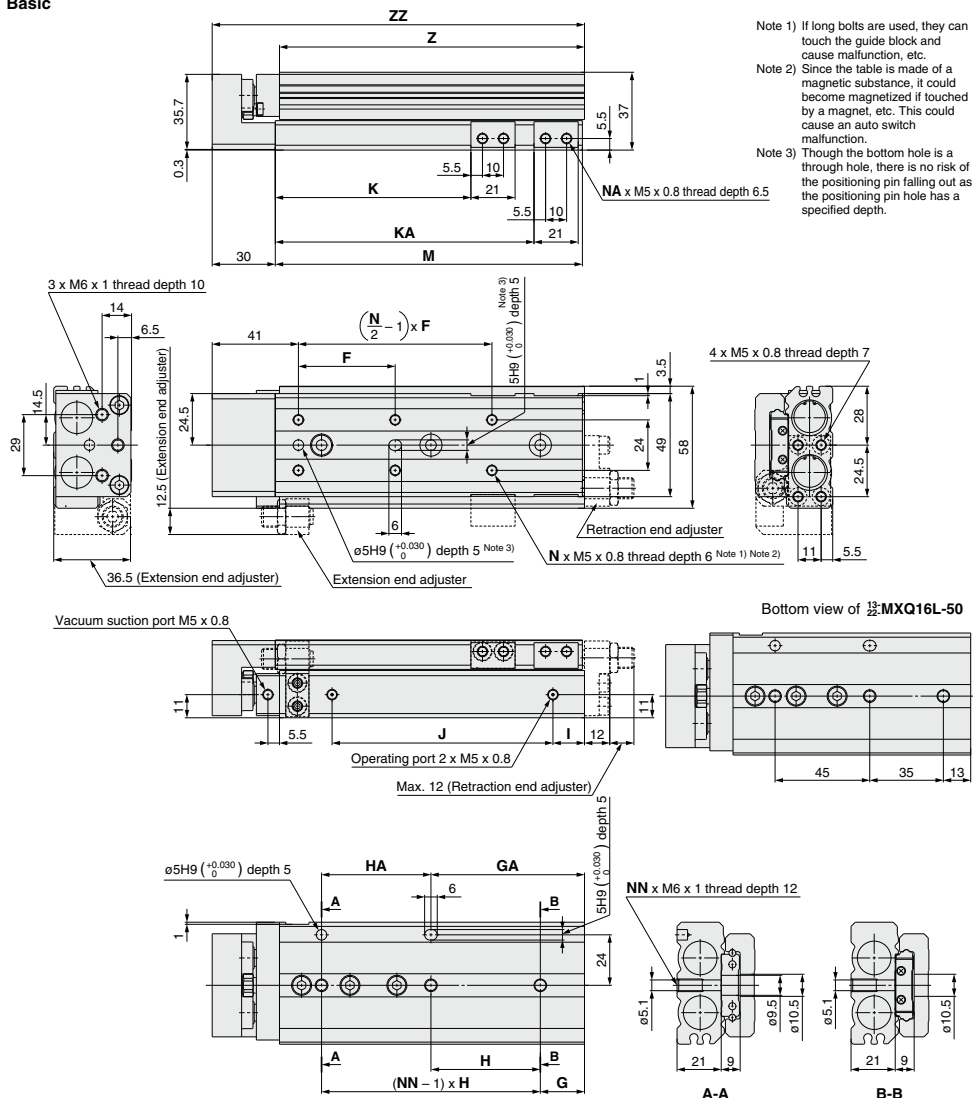

Model	F	N	G	H	NN	GA	HA	I	J	K	KA	NA	M	Z	ZZ
13-22-MXQ16L- 10	38	4	18	39	2	18	39	12	40	28	—	4	78	77	109
13-22-MXQ16L- 20	38	4	18	39	2	18	39	12	40	38	—	4	78	77	109
13-22-MXQ16L- 30	48	4	19	48	2	19	48	12	50	48	—	4	88	87	119
13-22-MXQ16L- 40	58	4	19	58	2	19	58	12	60	58	—	4	98	97	129
13-22-MXQ16L- 50	40	6	(Note)	(Note)	3	48	45	20	68	68	91	8	114	113	145
13-22-MXQ16L- 75	46	6	21	52	3	73	52	15	105	93	123	8	146	145	177
13-22-MXQ16L-100	44	8	36	44	4	80	88	18	145	118	166	8	189	188	220
13-22-MXQ16L-125	44	10	17	44	5	105	88	23	165	143	191	8	214	213	245

(mm)  
 Note) Refer to the bottom view of 13-22-MXQ16L-50.

**Dimensions: <sup>13-</sup>/<sub>22-</sub>MXQ16L / Symmetric Type**

Axial piping (ø16): <sup>13-</sup>/<sub>22-</sub>MXQ16L-□□P

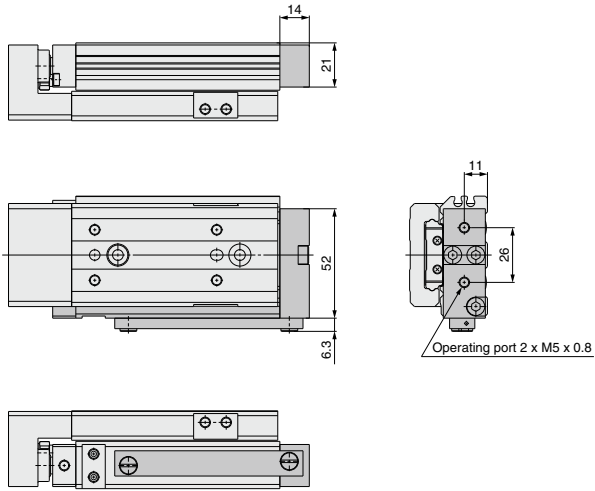

\* Other dimensions are the same as basic type.

Directional  
Control Valves

Air Cylinders

Rotary Actuators

Air Grippers

Air Preparation  
Equipment

Modular F. R.

Pressure Control  
Equipment

Fittings & Tubing

Flow Control  
Equipment

Pressure Switches/  
Pressure Sensors

**Dimensions:**  $\frac{13}{22}$ -**MXQ20**

**Basic**

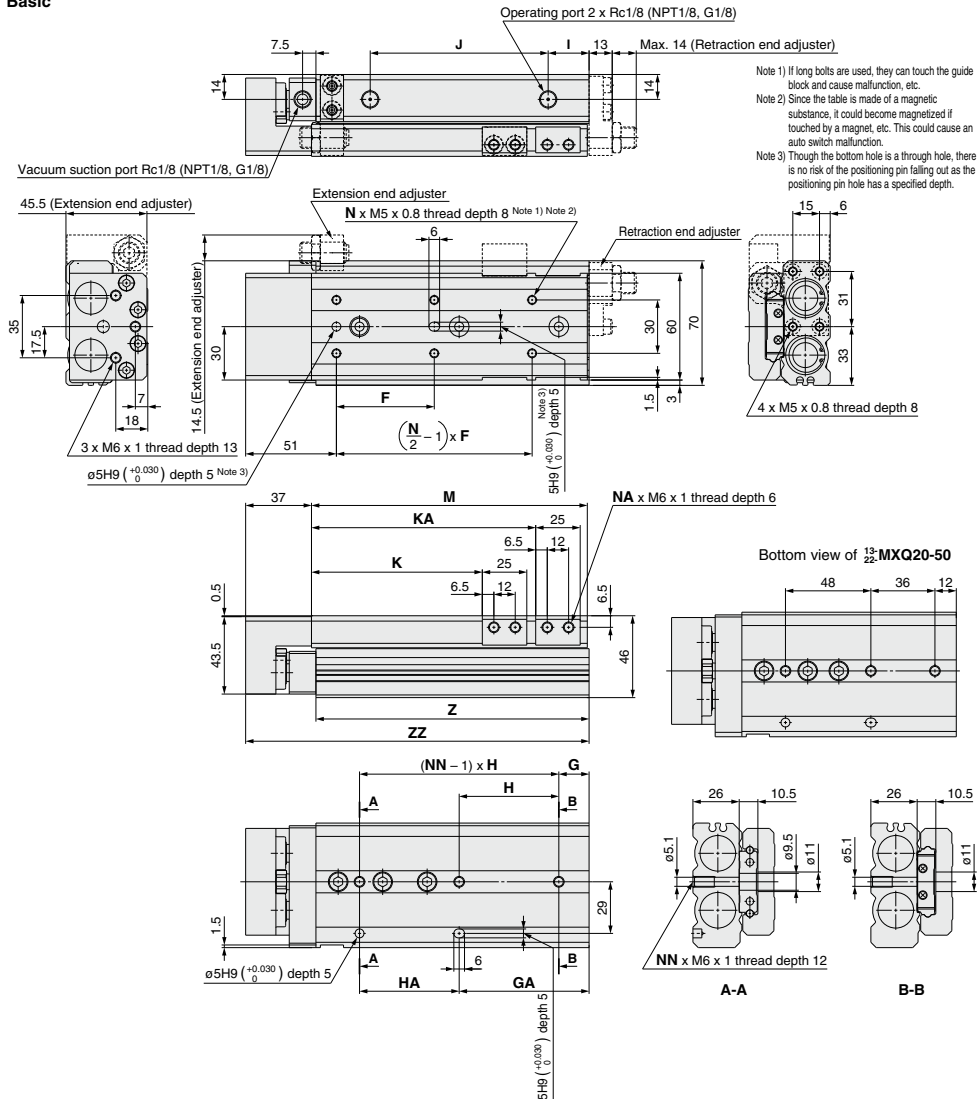

- Note 1) If long bolts are used, they can touch the guide block and cause malfunction, etc.
- Note 2) Since the table is made of a magnetic substance, it could become magnetized if touched by a magnet, etc. This could cause an auto switch malfunction.
- Note 3) Though the bottom hole is a through hole, there is no risk of the positioning pin falling out as the positioning pin hole has a specified depth.

Model	F	N	G	H	NN	GA	HA	I	J	K	KA	NA	M	Z	ZZ
13-/22-MXQ20- 10	45	4	22	46	2	18	50	16	46	31	—	4	94	92.5	132
13-/22-MXQ20- 20	40	4	22	46	2	18	50	16	46	41	—	4	94	92.5	132
13-/22-MXQ20- 30	48	4	22	46	2	18	50	16	46	51	—	4	94	92.5	132
13-/22-MXQ20- 40	58	4	22	56	2	22	56	16	56	61	—	4	104	102.5	142
13-/22-MXQ20- 50	42	6	$\frac{N}{2}$	$\frac{H}{2}$	3	48	48	18	72	71	—	4	122	120.5	160
13-/22-MXQ20- 75	55	6	17	56	3	73	56	23	100	96	126	8	155	153.5	193
13-/22-MXQ20-100	50	8	18	56	4	74	112	25	155	121	183	8	212	210.5	250
13-/22-MXQ20-125	55	8	37	59	4	96	118	18	190	146	211	8	240	238.5	278
13-/22-MXQ20-150	62	8	56	62	4	118	124	21	215	171	239	8	268	266.5	306

Note) Refer to the bottom view of  $\frac{13}{22}$ -MXQ20-50.

**Dimensions:** <sup>13-</sup><sub>22-</sub>MXQ20

Axial piping (ø20): <sup>13-</sup><sub>22-</sub>MXQ20-□□P

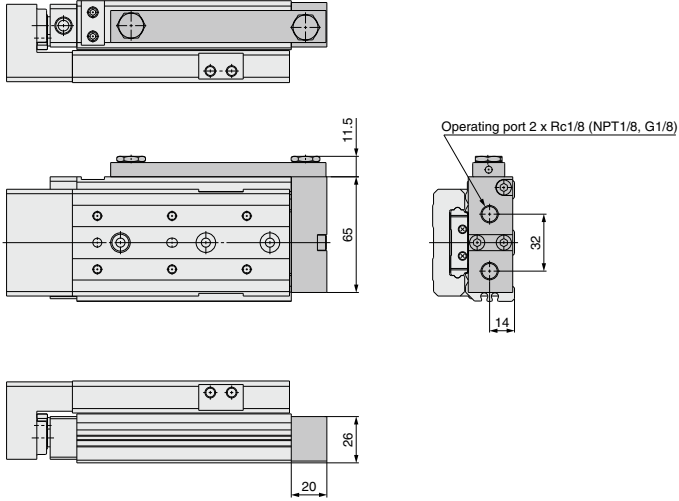

\* Other dimensions are the same as basic type.

Directional Control Valves

Air Cylinders

Rotary Actuators

Air Grippers

Air Preparation Equipment

Modular F. R.

Pressure Control Equipment

Fittings & Tubing

Flow Control Equipment

Pressure Switches/ Pressure Sensors

**Dimensions: 13-22-MXQ20L / Symmetric Type**

**Basic**

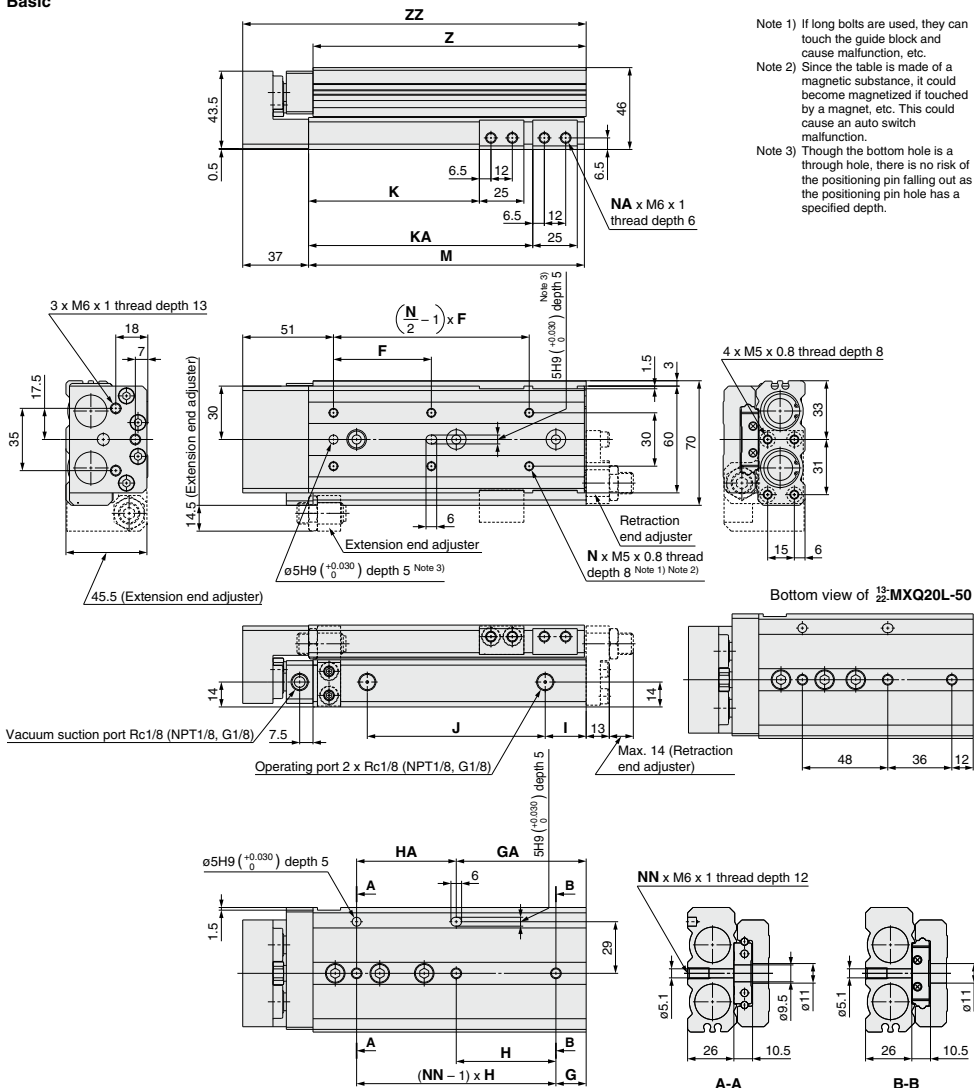

Model	F	N	G	H	NN	GA	HA	I	J	K	KA	NA	M	Z	ZZ
13-22-MXQ20L-10	45	4	22	46	2	18	50	16	46	31	—	4	94	92.5	132
13-22-MXQ20L-20	40	4	22	46	2	18	50	16	46	41	—	4	94	92.5	132
13-22-MXQ20L-30	48	4	22	46	2	18	50	16	46	51	—	4	94	92.5	132
13-22-MXQ20L-40	58	4	22	56	2	22	56	16	56	61	—	4	104	102.5	142
13-22-MXQ20L-50	42	6	<small>Note1</small>	<small>Note2</small>	3	48	48	18	72	71	—	4	122	120.5	160
13-22-MXQ20L-75	55	6	17	56	3	73	56	23	100	96	126	8	155	153.5	193
13-22-MXQ20L-100	50	8	18	56	4	74	112	25	155	121	183	8	212	210.5	250
13-22-MXQ20L-125	55	8	37	59	4	96	118	18	190	146	211	8	240	238.5	278
13-22-MXQ20L-150	62	8	56	62	4	118	124	21	215	171	239	8	268	266.5	306

Note) Refer to the bottom view of 13-22-MXQ20L-50.

**Dimensions: <sup>13-</sup>/<sub>22-</sub>MXQ20L / Symmetric Type**

Axial piping (ø20): <sup>13-</sup>/<sub>22-</sub>MXQ20L-□□P

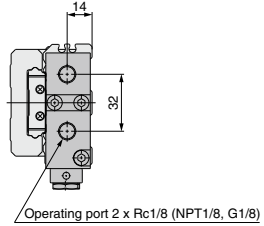
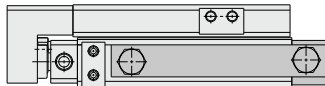
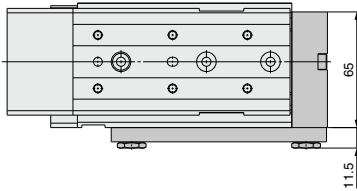

\* Other dimensions are the same as basic type.

Directional Control Valves

Air Cylinders

Rotary Actuators

Air Grippers

Air Preparation Equipment

Modular F. R.

Pressure Control Equipment

Fittings & Tubing

Flow Control Equipment

Pressure Switches/ Pressure Sensors



**Dimensions:** <sup>13-</sup><sub>22-</sub>MXQ25

Axial piping (ø25): <sup>13-</sup><sub>22-</sub>MXQ25-□□P

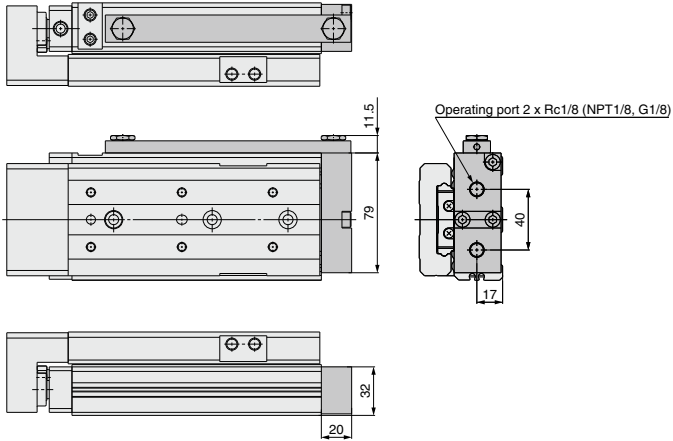

\* Other dimensions are the same as basic type.

Directional Control Valves

Air Cylinders

Rotary Actuators

Air Grippers

Air Preparation Equipment

Modular F. R.

Pressure Control Equipment

Fittings & Tubing

Flow Control Equipment

Pressure Switches/ Pressure Sensors





**Dimensions: 13-22-MXQ25L / Symmetric Type**

Axial piping (ø25): 13-22-MXQ25L-□□P

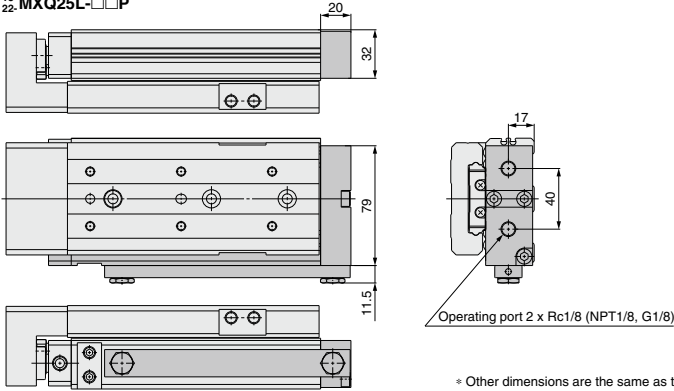

**Made to Order**

**1. Anti-corrosive guide unit -X42**

13-22-MXQ **Standard model no. -X42**

Martensitic stainless steel is used for table and guide block. Use this treatment if more effective anti-corrosiveness is necessary. Table and guide block are given anti-corrosive treatment <sup>Note 2)</sup>.

Note 1) Dimensions are the same as standard type.

Note 2) Special anti-corrosive treatment makes the table and guide block black.

**2. Dust cover and dust plug made by fluororubber -X52**

13-MXQ **Standard model no. -X52**

Fluororubber is used for the dust cover and the dust plug instead of silicone rubber for standard one.

Note 1) Dimensions are the same as standard type.

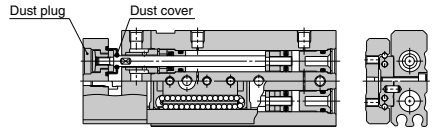

**⚠ Specific Product Precautions**

**Be sure to read this before handling.**

**Handling**

**⚠ Caution**

**In case the extension end stroke adjuster is removed, plug the mounting hole.**

Particle generation may occur because the bottom hole of the mounting screw penetrates the body.

Applicable bore size (mm)	12, 16, 20, 25
---------------------------	----------------

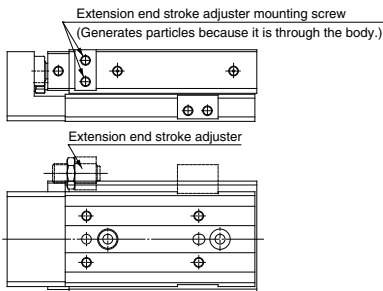

In case of types without extension end adjuster, the hole is plugged with a hexagon socket set screw at the time of shipment.

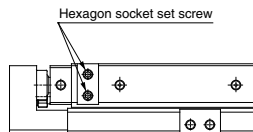

Directional Control Valves  
Air Cylinders  
Rotary Actuators  
Air Grippers  
Air Preparation Equipment  
Modular F. R.  
Pressure Control Equipment  
Fittings & Tubing  
Flow Control Equipment  
Pressure Switches/Pressure Sensors