



ORIGINAL INSTRUCTIONS

Instruction Manual

ISO Standard Solenoid Valve

EVS7-(6,8,10)-M0 Series



The intended use of this valve is to control the movement of an actuator.

1 Safety Instructions

These safety instructions are intended to prevent hazardous situations and/or equipment damage. These instructions indicate the level of potential hazard with the labels of "Caution," "Warning" or "Danger." They are all important notes for safety and must be followed in addition to International Standards (ISO/IEC<sup>\*)</sup>, and other safety regulations.

- \*) ISO 4414: Pneumatic fluid power - General rules relating to systems.
- ISO 4413: Hydraulic fluid power - General rules relating to systems.
- IEC 60204-1: Safety of machinery - Electrical equipment of machines. (Part 1: General requirements)
- ISO 10218-1: Robots and robotic devices - Safety requirements for industrial robots - Part 1: Robots.

- Refer to product catalogue, Operation Manual and Handling Precautions for SMC Products for additional information.
- Keep this manual in a safe place for future reference.

<b>Caution</b>	Caution indicates a hazard with a low level of risk which, if not avoided, could result in minor or moderate injury.
<b>Warning</b>	Warning indicates a hazard with a medium level of risk which, if not avoided, could result in death or serious injury.
<b>Danger</b>	Danger indicates a hazard with a high level of risk which, if not avoided, will result in death or serious injury.

**Warning**

- Always ensure compliance with relevant safety laws and standards.
- All work must be carried out in a safe manner by a qualified person in compliance with applicable national regulations.

**Caution**

- The product is provided for use in manufacturing industries only. Do not use in residential premises.

2 Specifications

2.1 Valve specifications

Valve type	Metal seal	Rubber seal
Fluid	Air	
Maximum operating pressure [MPa]	1.0	
Minimum operating pressure [MPa]	Single Solenoid	0.1
	Double Solenoid (2 position)	
	Double solenoid (3 position)	
Ambient and fluid temperature [°C]	-10 to 60 (No freezing)	-5 to 60 (No freezing)
Flow characteristics	Refer to catalogue	
Response time [ms]	Refer to Table 2.	
Duty cycle	Contact SMC	
Minimum operating frequency	1 cycle / 30 days	
Lubrication	Not required	
Manual override	Push type (Tool required)	

2 Specifications – continued

Impact / Vibration resistance [m/s <sup>2</sup> ] <sup>Note 2)</sup>	150 / 50
Enclosure (based on IEC60529)	IP65
Mounting orientation <sup>Note 3)</sup>	Unrestricted
Weight	Refer to catalogue

Table 1.

- Note 1) Use dry air to prevent condensation at low temperatures.
- Note 2) Impact resistance: No malfunction resulted during the impact test using a drop impact tester. The test was performed one time each in the axial and right angle directions of the main valve and armature for both energized and de-energized conditions. (Values quoted are for a new valve)  
Vibration resistance: No malfunction resulted during a one-sweep test between 8.3 and 2000 Hz. The test was performed in the axial and right angle directions of the main valve and armature for both energized and de-energized conditions. (Values quoted are for a new valve)
- Note 3) If there is vibration or impact, install the valve so that the spool is perpendicular to the direction of vibration.  
If there is no vibration or impact, install the spool valve so that it is horizontal.

2.1.1 Response time

Series size	Valve type	Response times [ms]	
		Rubber seal	Metal seal
EVS7-6	Single solenoid	<35	<30
	Double solenoid	<30	<25
	3 position	<55	
EVS7-8	Single solenoid	<60	<50
	Double solenoid	<50	<25
	3 position	<70	
EVS7-10	Single solenoid	<80	<50
	Double solenoid	<50	<25
	3 position	<95	<70

Table 2.

Note: Response time values for reference only.

2.2 Solenoid specifications

Rated coil voltage [VDC]	12, 24	
Electrical entry	M12 connector	
Allowable voltage fluctuation <sup>Note 1)</sup>	-15 to +10% of rated voltage	
Type of coil insulation	Equivalent to Class B	
Power consumption (W)	24 VDC	1.8 (75mA)
	12 VDC	1.8 (150mA)
Surge voltage suppressor	Zener diode	
Indicator light	LED (Green A and B side)	

Table 3.

Note 1) Valve state is not defined if electrical input is outside of specified operating ranges.

2.3 Pneumatic symbols

Refer to catalogue for pneumatic symbols.

2.4 Indicator light

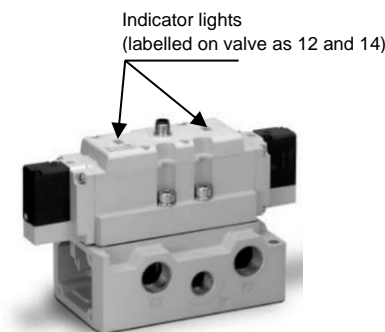

Figure 1. Indicator lights location

2.5 Special products

**Warning**

Special products (-X) might have specifications different from those shown in this section. Contact SMC for specific drawings.

3 Installation

3.1 Installation

**Warning**

- Do not install the product unless the safety instructions have been read and understood.

3.2 Environment

**Warning**

- Do not use in an environment where corrosive gases, chemicals, salt water or steam are present.
- Do not use in an explosive atmosphere.
- Do not expose to direct sunlight. Use a suitable protective cover.
- Do not install in a location subject to vibration or impact in excess of the product's specifications.
- Do not mount in a location exposed to radiant heat that would result in temperatures in excess of the product's specifications.
- Products compliant with IP65 and IP67 enclosures (Based on IEC60529) are protected against dust and water, however, these products cannot be used in water.
- Products compliant with IP65 and IP67 enclosures satisfy the specifications by mounting each product properly. Be sure to read the Specific Product Precautions for each product.
- Do not use in high humidity environment where condensation can occur.
- Contact SMC for altitude limitations.

3.3 Piping and fittings

**Caution**

- Before connecting piping make sure to clean up chips, cutting oil, dust etc.
- When installing piping or fittings, ensure sealant material does not enter inside the port. When using seal tape, leave 1 thread exposed on the end of the pipe/fitting.

3.3.1 Tightening torque

**Caution**

Tighten fittings to the specified tightening torque.

Connection thread size (R, NPT)	Tightening torque [N·m]
1/4	8 to 12
3/8	15 to 20
1/2	20 to 25
3/4	28 to 30

Table 4.

3.3.2 One-touch fittings tubing attachment and detachment

**Caution**

Refer to Fittings & Tubing Precautions.

3.3.3 Other tube brands

**Caution**

When using non-SMC brand tubes, refer to Fittings & Tubing Precautions.

3.4 Lubrication

**Caution**

- SMC products have been lubricated for life at manufacture, and do not require lubrication in service.
- If a lubricant is used in the system, refer to catalogue for details.

3.5 Air supply

**Warning**

- Use clean air. If the compressed air supply includes chemicals, synthetic materials (including organic solvents), salinity, corrosive gas etc., it can lead to damage or malfunction.

**Caution**

- Install an air filter upstream of the valve. Select an air filter with a filtration size of 5µm or smaller.

3 Installation - continued

3.6 Manual override

**Warning**

- Regardless of an electric signal for the valve, the manual override is used for switching the main valve. Since connected equipment will operate when the manual override is activated, confirm that conditions are safe prior to activation.

**Warning**

- To operate the manual override, use tool to push the manual override until it stops.
- Refer to catalogue for manual override location.

3.7 Mounting

3.7.1 Mounting valves to subplate or manifold

**Caution**

Series size	Screw size	Tightening torque [N·m]
EVS7-6	M5	2.3 to 3.7
	M5	
EVS7-8	M6	4 to 6
	M6	
EVS7-10	M8	11 to 15
	M8	

Table 5.

- Ensure all ports are correctly identified and piped, all ports are indicated on the valve, subplate and manifold base.
- Ensure gaskets are in good condition, not deformed and are dust and debris free.
- When mounting valves ensure gaskets are present, aligned and securely in place and tighten screws to the torque value indicated in table 5.

3.8 Electrical circuits

**Caution**

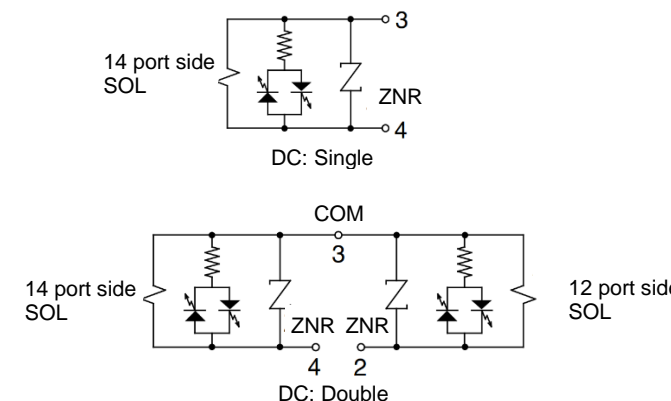

Figure 2. EVS7-M0 electrical circuits

3.9 Electrical connections

**Caution**

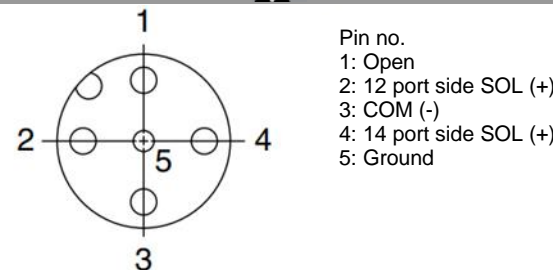

Figure 3. M12 connector wiring specification

### 3 Installation - continued

#### 3.10 Light/Surge voltage suppressor

##### ⚠ Caution

- Refer to Figure 2 for surge voltage suppressor diagrams.
- Surge voltage generated when OFF is about 60 V. Please contact SMC for further suppression of the coil surge voltage.
- In the case of valve without surge voltage suppressor the machine designer shall add suppression as close as possible to the valve.

#### 3.11 Residual voltage

##### ⚠ Caution

- If a Zener diode or varistor voltage suppressor is used, the suppressor arrests the back EMF voltage from the coil to a level in proportion to the rated voltage.
- Ensure the transient voltage is within the specification of the host controller.
- Contact SMC for the Zener diode or varistor residual voltage.
- Valve response time is dependent on surge suppression method selected.

#### 3.12 Countermeasure for surge voltage

##### ⚠ Caution

- At times of sudden interruption of the power supply, the energy stored in a large inductive device may cause non-polar type valves in a de-energised state to switch.
- When installing a breaker circuit to isolate the power, consider a valve with polarity (with polarity protection diode), or install a surge absorption diode across the output of the breaker.

#### 3.13 Extended period of continuous energization

##### ⚠ Warning

If a valve will be continuously energized for an extended period of time, the temperature of the valve will increase due to the heat generated by the coil assembly. This will likely adversely affect the performance of the valve and any nearby peripheral equipment. Therefore, if the valve is to be energized for periods of longer than 30 minutes at a time or if during

the hours of operation the energized period per day is longer than the de-energized period, we advise using a valve with specifications of 0.4 W or lower valve, such as the SY series, or a valve with a power-saving circuit.

#### 3.14 Effect of back pressure when using a manifold

##### ⚠ Warning

- Use caution when valves are used on a manifold, because an actuator may malfunction due to back-pressure.
- Special caution must be taken when using 3 position exhaust centre valve or when driving a single acting cylinder. To prevent a malfunction, implement counter measures such as using a single EXH spacer assembly or an individual exhaust manifold.

### 4 How to Order

Refer to catalogue for 'How to Order' or to product drawing for special products.

### 5 Outline Dimensions

Refer to catalogue for outline dimensions.

### 6 Maintenance

#### 6.1 General maintenance

##### ⚠ Caution

- Not following proper maintenance procedures could cause the product to malfunction and lead to equipment damage.
- If handled improperly, compressed air can be dangerous.
- Maintenance of pneumatic systems should be performed only by qualified personnel.
- Before performing maintenance, turn off the power supply and be sure to cut off the supply pressure. Confirm that the air is released to atmosphere.
- For 3 position closed centre valves, exhaust the residual pressure between the valve and the cylinder.

### 6 Maintenance - continued

- After installation and maintenance, apply operating pressure and power to the equipment and perform appropriate functional and leakage tests to make sure the equipment is installed correctly.
- If any electrical connections are disturbed during maintenance, ensure they are reconnected correctly and safety checks are carried out as required to ensure continued compliance with applicable national regulations.
- Do not make any modification to the product.
- Do not disassemble the product, unless required by installation or maintenance instructions.

#### 6.2 Mounting

##### ⚠ Caution

- Ensure all ports are correctly identified and piped, all ports are indicated on the valve, subplate and manifold base.
- Ensure gaskets are in good condition, not deformed and are dust and debris free.
- When mounting valves ensure gaskets are present, aligned and securely in place and tighten screws to the torque value indicated in table 5.

### 7 Limitations of Use

##### ⚠ Warning

The system designer should determine the effect of the possible failure modes of the product on the system.

#### 7.1 Limited warranty and disclaimer/compliance requirements

Refer to Handling Precautions for SMC Products.

#### 7.2 Return of the spool to the de-energisation position

##### ⚠ Warning

	Single solenoid	Double solenoid	3 position
Air supply present, electrical supply cut	Valve spool returns to the OFF position by air and spring force.	Valve spool holds position.	Valve spool returns to the OFF position by spring force.
Electrical supply present, air supply cut	Valve spool returns to the OFF position by spring force.	Valve spool holds position.	Valve spool returns to the OFF position by spring force.

Table 6.

#### 7.3 Intermediate stopping

##### ⚠ Warning

Refer to Handling Precautions for 3/4/5 port Solenoid Valves.

#### 7.4 Holding of pressure

##### ⚠ Warning

Since valves are subject to air leakage, they cannot be used for applications such as holding pressure (including vacuum) in a pressure system.

#### 7.5 Cannot be used as an emergency shut-off valve

##### ⚠ Warning

This product is not designed for safety applications such as an emergency shut-off valve. If the valves are used in this type of system, other reliable safety assurance measures should be adopted.

#### 7.6 Safety relays or PLC

##### ⚠ Warning

If a safe output from a safety relay or PLC is used to operate this valve, ensure that any output test pulse duration is shorter than 1 ms to avoid the valve solenoid responding.

### 7 Limitations of Use - continued

#### 7.7 Leakage voltage

##### ⚠ Caution

Ensure that any leakage voltage caused by the leakage current when the switching element is OFF causes  $\leq 3\%$  of the rated voltage across the valve.

#### 7.8 Low temperature operation

##### ⚠ Caution

Unless otherwise indicated in the specifications for each valve, operation is possible to  $-5^{\circ}\text{C}$  (rubber seal) /  $-10^{\circ}\text{C}$  (metal seal), but appropriate measures should be taken to avoid solidification or freezing of drainage and moisture, etc.

#### 7.9 Momentary energisation

##### ⚠ Caution

If a double solenoid valve is operated with momentary energization, it should be energized for at least 0.1 second. However, depending on the secondary load conditions, it should be energized until the cylinder reaches the stroke end position, as there is a possibility of malfunction otherwise.

### 8 Product Disposal

This product shall not be disposed of as municipal waste. Check your local regulations and guidelines to dispose this product correctly, in order to reduce the impact on human health and the environment.

### 9 Contacts

Refer to [www.smcworld.com](https://www.smcworld.com) or [www.smc.eu](https://www.smc.eu) for your local distributor/importer.

## SMC Corporation

URL : <https://www.smcworld.com> (Global) <https://www.smc.eu> (Europe)  
SMC Corporation, 4-14-1, Sotokanda, Chiyoda-ku, Tokyo 101-0021, Japan  
Specifications are subject to change without prior notice from the manufacturer.  
© 2021 SMC Corporation All Rights Reserved.  
Template DKP50047-F-085M