

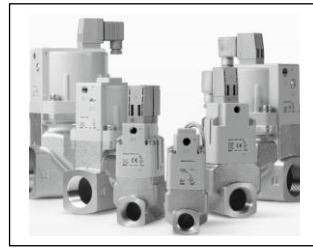

ORIGINAL INSTRUCTIONS

**Instruction Manual**  
**Coolant Valve**  
**Series SGC(A)**



The intended use of this valve is to control the supply of liquid coolant.

**1 Safety Instructions**

These safety instructions are intended to prevent hazardous situations and/or equipment damage. These instructions indicate the level of potential hazard with the labels of "Caution," "Warning" or "Danger." They are all important notes for safety and must be followed in addition to International Standards (ISO/IEC<sup>1)</sup>, and other safety regulations.

<sup>1)</sup>ISO 4414: Pneumatic fluid power - General rules and safety requirements for systems and their components.

ISO 4413: Hydraulic fluid power - General rules and safety requirements for systems and their components.

IEC 60204-1: Safety of machinery - Electrical equipment of machines. Part 1: General requirements

ISO 10218-1: Robots and robotic devices - Safety requirements for industrial robots - Part 1: Robots

- Refer to product catalogue, Operation Manual and Handling Precautions for SMC Products for additional information.
- Keep this manual in a safe place for future reference.

<b>Danger</b>	Danger indicates a hazard with a high level of risk which, if not avoided, will result in death or serious injury.
<b>Warning</b>	Warning indicates a hazard with a medium level of risk which, if not avoided, could result in death or serious injury.
<b>Caution</b>	Caution indicates a hazard with a low level of risk which, if not avoided, could result in minor or moderate injury.

**Warning**

- **Always ensure compliance with relevant safety laws and standards.**
- All work must be carried out in a safe manner by a qualified person in compliance with applicable national regulations.
- If this equipment is used in a manner not specified by the manufacturer, the protection provided by the equipment may be impaired.

**Caution**

- The product is provided for use in manufacturing industries only. This product must not be used in residential areas.

**2 Specifications**

**2.1 Valve specifications**

	SGC(A)-05	SGC(A)-10	SGC(A)-16
Fluid	Coolant (Water cannot be used)		
Operating pressure range [MPa] <sup>Note 1)</sup>	0 to 0.5	0 to 0.10	0 to 1.6 <sup>Note 2)</sup>
External pilot operating pressure range [MPa]	SGC(A)##1	0.25 to 0.7	
	SGC(A)##2	0.25 to 0.7 (for 0.5 MPa type)	0.3 to 0.7 (for 1 and 1.6 MPa type)
Proof pressure [MPa]	SGC(A)(2, 3, 4)	2.4	
	SGC(A)(5, 6, 7)	1.5	
Leakage from valve seat [cm <sup>3</sup> /min]	20 or less (Coolant pressure)		
Ambient temperature [°C]	-5 to 50 (No freezing)		
Fluid temperature [°C]	-5 to 60 (No freezing)		

**2 Specifications - continued**

External pilot air temperature [°C]	-5 to 50 (No freezing)
Pressure dew point (minimum) [°C]	-20
Air quality	ISO 8573-1:2010 [6:5:3] 6 – Solid particles: ≤ 5 µm 5 – Pressure dew point: ≤ 7°C 3 – Total percentage of oil: ≤ 1 mg/m <sup>3</sup>
Flow characteristics	Refer to catalogue
Response time [ms] <sup>Note 3)</sup>	Contact SMC
Duty cycle	Contact SMC
Min. operating frequency	1 cycle / 30 days
Max. operating frequency [Hz]	Contact SMC
Manual override	Non-locking push / Locking push-turn
Lubrication	Not required
Impact/Vibration resistance [m/s <sup>2</sup> ] <sup>Note 4)</sup>	150/30
Mounting orientation <sup>Note 5)</sup>	Restricted
Wetted parts	Body assembly: Cast iron, Plate assembly: Iron, NBR/FKM, Valve body: SUS, Valve cover: NBR/FKM
Weight	Refer to catalogue

Table 1.

Note 1) The pressure differential between Port 1 (A) and Port 2(B) must not exceed the maximum operating pressures.

Note 2) Series 2, 3, 4 only.

Note 3) Response time depends on the pilot valve, pressure, and piping conditions.

Note 4) Impact resistance: No malfunction occurred when it was tested with a drop tester in the axial direction and at right angles to the main valve and armature; in both energized and de-energized states and for every time in each condition. (Values quoted are for a new valve)

Vibration resistance: No malfunction occurred in a one-sweep test between 45 and 2000 Hz. Tests are performed at both energized and de-energized states in the axial direction and at right angles to the main valve and armature. (Values quoted are for a new valve).

Note 5) Mounting is restricted as coil should not be mounted downwards. This is to prevent foreign matter from entering the plate assembly part.

**2.2 Solenoid specifications**

Pilot valve		VO307
Coil rated voltage	DC [VDC]	12, 24
	AC [VAC]	100, 110, 200, 220
Electrical entry		DIN, M12
Coil insulation class		Class B
Allowable voltage fluctuation		-15% to 10% of rated voltage
Apparent power [VA]	Inrush	12.7 [50Hz] / 10.7 [60Hz]
	Holding	7.6 [50Hz] / 5.4 [60Hz]
Power consumption [W] (with light)		1.8 (2.0)
Surge voltage suppressor	DC	Diode
	AC	Varistor
Indicator light (AC with DIN/M12)		LED
Enclosure (based on IEC60529)		IP40

Table 2.

Pilot valve		V116
Coil rated voltage	DC [VDC]	12, 24
	AC [VAC]	100, 110 (115), 200, 220 (230) <sup>Note 1)</sup>
Electrical entry		Conduit, DIN, M12
Coil insulation class		Class B
Allowable voltage fluctuation <sup>Note 2, 3)</sup>		±10% of rated voltage
Apparent power (With indicator light) [VA]	100V	0.78 (0.87)
	100V [115V]	0.86 (0.97) [0.94 (1.07)]
	200V	1.15 (1.30)
	220V [230V]	1.27 (1.46) [1.39 (1.60)]
Power consumption [W] (with light)		0.35 (0.58)
Surge voltage suppressor		Varistor
Indicator light		LED (Neon light)
Enclosure (based on IEC60529)		IP65

Table 3.

Note 1) Common solenoid between 110 & 115VAC, and between 220 & 230VAC.  
Note 2) Valve state is not defined if electrical input is outside of specified operating ranges.

Note 3) For the V116 pilot valve at 115 or 230VAC, voltage fluctuation is -15% to +5% of rated voltage.

**2 Specifications - continued**

**2.3 Auto switch specifications**

Auto switch model	D-M9N(A)	D-M9P(A)	D-M9B(A)
Refer to Instruction Manual for D-M9 for additional specifications.			

**2.4 Indicator light**

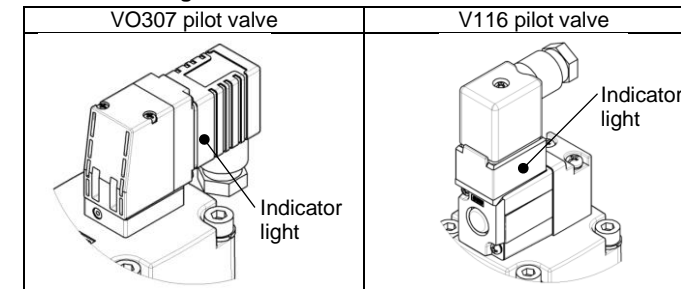

Table 4.

**2.5 Pneumatic symbols**

Type of actuation	N.C.	N.O.
Air operated		
External pilot solenoid		

Table 5.

**2.6 Special products**

**Warning**

Special products (-X) might have specifications different from those shown in this section. Contact SMC for specific drawings.

**3 Installation**

**3.1 Installation**

**Warning**

- Do not install the product unless the safety instructions have been read and understood.
- If leakage causes associated equipment to malfunction cease using the valve and inspect for cause.
- Check fixings while pressure and power are applied. Initial function and leakage should be performed after installation.
- Allow sufficient space for maintenance and inspection.
- Do not paint any part of this product.
- When problems are caused by water hammer, install water hammer relief equipment. (accumulator, etc.)

**3.2 Environment**

**Warning**

- Do not use in an environment where corrosive gases, chemicals, salt water or steam are present.
- Do not use in an explosive atmosphere.
- Do not expose to direct sunlight. Use a suitable protective cover.
- Do not install in a location subject to vibration or impact in excess of the product's specifications.
- Do not mount in a location exposed to radiant heat that would result in temperatures in excess of the product's specifications.
- Products compliant with IP65 enclosures are protected against dust and water, however, these products cannot be used in water.
- Products compliant with IP65 enclosures satisfy the specifications by mounting each product properly. Be sure to read the Specific Product Precautions for each product.
- Do not use in an area where a magnetic field is generated. Auto switches can malfunction or magnets inside valve can become demagnetized.

**3 Installation - continued**

- Do not use in an environment where there are cyclic temperature changes. Temperature cycles other than normal temperature changes can adversely affect the auto switch internally.
- Avoid accumulation of iron debris or close contact with magnetic substances. When a large amount of iron waste such as machining chips or spatter has accumulated, or a magnetic substance (something attracted by a magnet) is brought into close proximity with the valve, it may cause the auto switch to malfunction due to a weakening of the magnetic force inside the valve.
- Do not use in high humidity environment where condensation can occur.
- Altitude limitation is 1000 m above sea level.

**Caution**

- Temperature of ambient environment. Use the valve within the range of the ambient temperature specification of each valve. In addition, pay attention when using the valve in environments where the temperature changes drastically.

**3.3 Piping**

**Caution**

- Before connecting piping make sure to clean up chips, cutting oil, dust etc.
- When installing piping or fittings, ensure sealant material does not enter inside the port. When using seal tape, leave 1.5 to 2 threads exposed on the end of the pipe/fitting.
- Tighten fittings to the specified tightening torque.

Connection thread (Rc, G, NPT, NPTF)	Tightening torque [N·m]
1/8	7 to 9
1/4	12 to 14
3/8	22 to 24
1/2	28 to 30
3/4	45 to 50
1	65 to 70
1 1/4	80 to 90
1 1/2	100 to 110
2	140 to 150

Table 6.

**3.4 Lubrication**

**Caution**

- SMC products have been lubricated for life at manufacture, and do not require lubrication in service.
- If a lubricant is used in the system, refer to catalogue for details.

**3.5 Wiring**

**Warning**

- Refer to Instruction Manual of auto switch D-M9#A for additional details.
- Ensure auto switch lead wires are secured to avoid tension in the wires when mounted.

**3.6 Fluid supply**

**Warning**

- The use of a fluid that contains foreign matter can cause problems, such as malfunction and seal failure by promoting the wear of the valve seat and armature, by sticking to the sliding parts of the armature, etc.
- Install a suitable filter (strainer) immediately upstream of the valve.
- The valve is designed for use with coolant only. Do not use with water. The wetted parts are cast iron and will rust if used with improper fluids.

**3.7 Pilot air supply**

**Warning**

- Use clean air. If the compressed air supply includes chemicals, synthetic materials (including organic solvents), salinity, corrosive gas etc., it can lead to damage or malfunction.

**Caution**

- Install an air filter upstream of the valve. Select an air filter with a filtration size of 5µm or smaller.

### 3 Installation - continued

#### 3.8 Coolant filtration

##### Caution

- 80-100 mesh filtration is recommended in the coolant line to reduce the risk of seal failure of the main valve.
- Although the product has a scraper to prevent foreign matter from entering the product, fluid containing fine foreign matter such as abrasive powder may cause sealing failure by the foreign matter adhering to the rod sliding part. Perform periodic maintenance or take countermeasures. Sealing failure of the rod sliding surface will allow reverse flow of the fluid into the pilot air piping, entering the pilot valve or circuit connected to the pilot air piping, causing adverse effects such as operation failure or leakage.

#### 3.9 Manual override

##### Warning

- Manual override is used to switch the main valve without inputting an electrical signal for the valve. When manual operation is performed, the connected actuator will start operating, so be sure to confirm that it is safe to operate beforehand.
- Locked manual overrides might prevent the valve responding to being electrically de-energised or cause unexpected movement in the equipment.
- Refer to the catalogue for details of manual override operation.
- Do not apply excessive torque when turning the locking type manual override (0.1N·m or less).

#### 3.10 Mounting

##### Warning

Do not install with the coil downwards. If a valve is mounted with the coil positioned downwards, foreign objects in the fluid will adhere to the core/armature leading to a malfunction.

#### 3.10.1 Bracket mounting

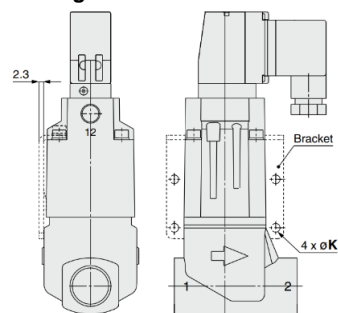

Figure 1.

#### 3.10.2 Auto switch mounting

##### Caution

- Fix the auto switch with the existing screw installed on the auto switch body. The auto switch may be damaged if a screw other than the one supplied is used.

Voltage	Colour
110 VAC	Blue
200 VAC	Red
DC	Red (+), Black (-)
Other	Grey

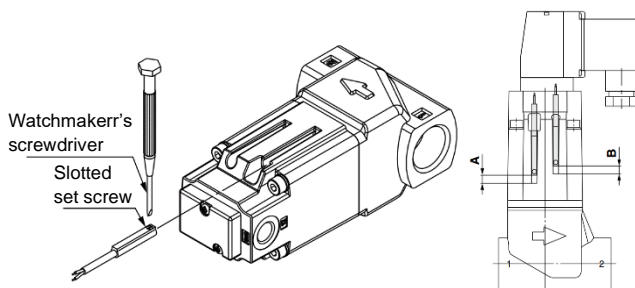

Figure 2.

### 3 Installation - continued

- For mounting position dimensions (A and B), refer to catalogue.
- When tightening an auto switch mounting screw, use a watchmaker's screwdriver with a handle of approximately 5 to 6mm in diameter.
- Furthermore, use a tightening torque of approximately 0.05 to 0.15 N·m or 0.05 to 0.1 N·m for D-M9#A.

#### 3.11 Electrical circuits

##### Caution

Surge suppression should be specified by using the appropriate part number. If a valve type without suppression (Type 'Nil') is used, suppression must be provided by the host controller as close as possible to the valve.

#### 3.11.1 VO307 pilot surge voltage suppression

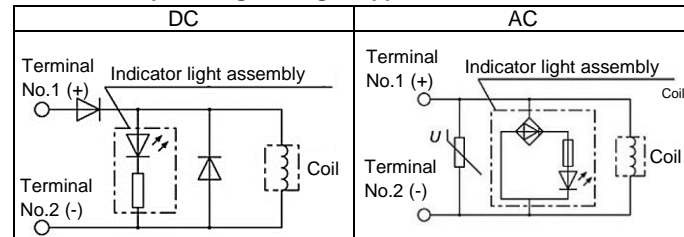

Table 7.

#### 3.11.2 V116 pilot valve

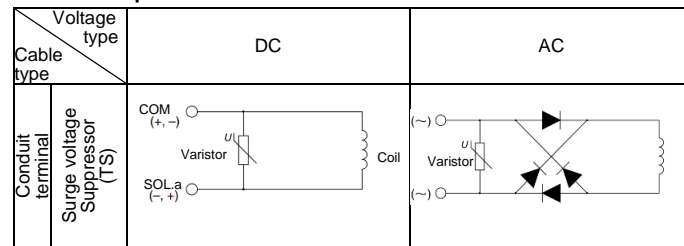

Table 8.

#### 3.12 Electrical connectors

#### 3.12.1 V116 pilot valve

##### Caution

- For conduit and DIN terminals, use cable with O.D. of Ø4.5 mm to Ø7 mm (reference: 0.5 mm<sup>2</sup> to 1.5 mm<sup>2</sup>, 2 core or 3 core wires equivalent to JIS C 3306).
- Tighten the ground nut and screws within the specified torque range.
- Refer to catalogue for additional details.

### 3 Installation - continued

#### 3.12.1.1 DIN terminal

##### Circuit Diagram with light/surge voltage suppressor

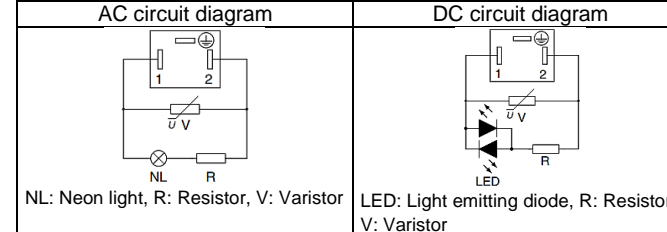

Table 9.

#### How to use DIN terminal

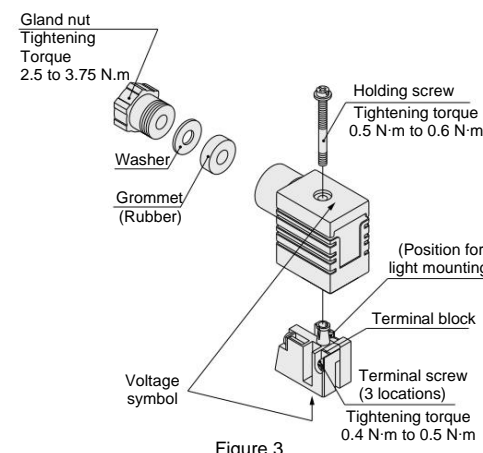

Figure 3.

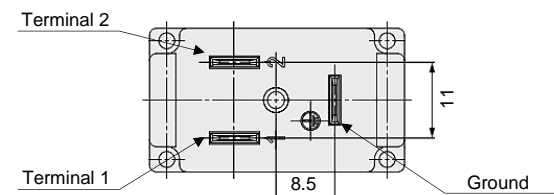

Figure 4.

##### Warning

The ground terminal is connected to the coil assembly only and does not provide a protective earth for the body of the valve.

#### 3.12.1.2 How to use conduit terminal

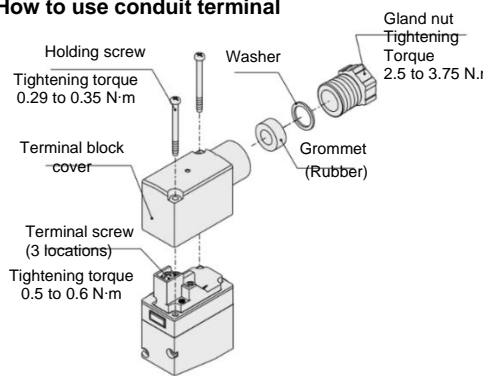

Figure 5.

#### 3.12.1.3 M12 connector

##### Caution

- Do not use a tool to mount the connector, as this may cause damage. Only tighten by hand (recommended tightening torque: 0.4 to 0.6 N·m)
- The excessive stress on the cable connector will not be able to satisfy the IP65 rating. Please use caution and do not apply a stress of 30 N or greater.

### 3 Installation - continued

Pin assignment of M12 connector on valve side			
4-pin type		5-pin type	
2 (unused)	1 (grounding)	2 (unused)	1 (unused)
3 (power supply)	4 (power supply)	3 (power supply)	5 (grounding)
DC Note 2)	AC Note 1)	DC Note 2)	AC
•	•	•	-

Table 10.

Note 1) For AC, a surge voltage suppressor or light/surge voltage suppressor can be selected.

Note 2) For DC specifications; 0.35 W type (Pilot valve V116) has no polarity. 1.8 W type (Pilot valve VO307) has polarity, pin no. 3(-) and pin no. 4(+).

#### 3.12.2 VO307 pilot valve

#### 3.12.2.1 How to use DIN terminal

- Use cable with O.D. of Ø6 mm to Ø8 mm.
- Tighten screws within the specified torque range.
- Refer to catalogue for additional details.

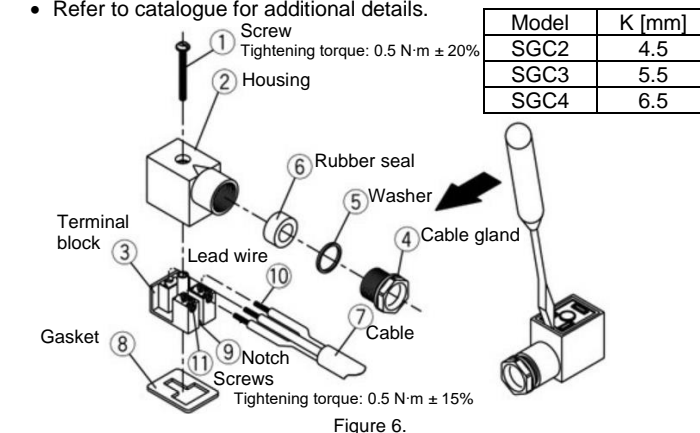

Figure 6.

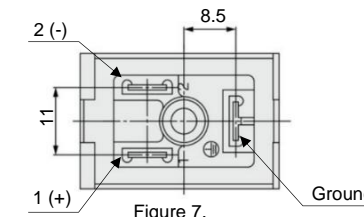

Figure 7.

##### Warning

The ground terminal is connected to the coil assembly only and does not provide a protective earth for the body of the valve.

#### 3.13 Residual voltage

##### Caution

- If a Zener diode or varistor voltage suppressor is used, the suppressor arrests the back EMF voltage from the coil to a level in proportion to the rated voltage.
- Ensure the transient voltage is within the specification of the host controller.
- In the case of a diode, the residual voltage is approximately 1 V.
- Valve response time is dependent on surge suppression method selected.

#### 3.14 Countermeasure for surge voltage

##### Caution

- At times of sudden interruption of the power supply, the energy stored in a large inductive device may cause non-polar type valves in a de-energised state to switch.
- When installing a breaker circuit to isolate the power, consider a valve with polarity (with polarity protection diode), or install a surge absorption diode across the output of the breaker.

### 3 Installation - continued

#### 3.15 Extended period of continuous energization

##### Warning

If a valve is continuously energized for long periods, heat generation of the coil may result in reduced performance and shorter service life. This may also have an adverse effect on the peripheral equipment in proximity. Should a valve be continuously energized for long periods, or its daily energized state exceeds its non-energised state, please use an energy saving type valve with DC voltage. Additionally, when using with AC voltage, energizing for long periods of time continuously, select the air-operated valve and use the continuous duty type of the VT307 for a pilot valve.

### 4 How to Order

Refer to catalogue for 'How to Order'.

### 5 Outline Dimensions

Refer to catalogue for outline dimensions.

### 6 Maintenance

#### 6.1 General maintenance

##### Caution

- Not following proper maintenance procedures could cause the product to malfunction and lead to equipment damage.
- If handled improperly, compressed air can be dangerous.
- Maintenance of pneumatic systems should be performed only by qualified personnel.
- Before performing maintenance, turn off the power supply and be sure to cut off the supply pressure. Confirm that the air is released to atmosphere.
- After installation and maintenance, apply operating pressure and power to the equipment and perform appropriate functional and leakage tests to make sure the equipment is installed correctly.
- If any electrical connections are disturbed during maintenance, ensure they are reconnected correctly and safety checks are carried out as required to ensure continued compliance with applicable national regulations.
- Do not make any modification to the product.

- Do not disassemble the product, unless required by installation or maintenance instructions.
- Valves will reach high temperatures when used with high temperature fluids. Use caution, as there is a danger of being burned if valve is touched directly.
- Perform the following maintenance periodically in order to prevent possible danger due to unexpected auto switch malfunction.
  - 1) Securely tighten switch mounting screws. If screws become loose or the mounting position is dislocated, retighten them after readjusting the mounting position.
  - 2) Confirm that there is no damage to lead wires. To prevent faulty insulation, replace switches or repair lead wires, etc., if damage is discovered.

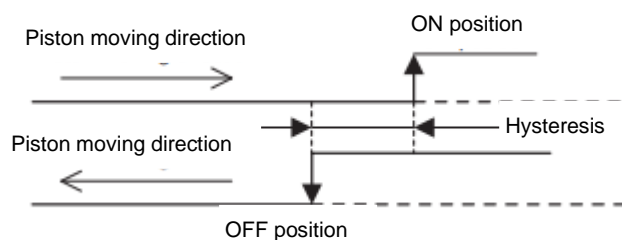

Figure 8

#### 6.2 Filters and strainers

- Replace filter elements after one year of use, or earlier, if the pressure drop reaches 0.1 MPa.
- Clean strainers when the pressure drop reaches 0.1 MPa.
- Storage: In case of long-term storage after use with heated water, thoroughly remove all moisture to prevent corrosion, and deterioration of rubber materials etc.
- Drain flushing: Remove drainage from air filters regularly. (Refer to the specifications)

### 6 Maintenance - continued

##### Warning

- Do not disassemble the product, the safety of products which have been disassembled cannot be guaranteed. In particular, the C type retaining ring inside the cover of the N.C. type valve and the bolt on the cover of the 3-port dual pressure specification must not be removed. Removal may result in the cover, piston, or spring popping out, which may result in an accident. Never remove the C type retaining ring or the bolt.
- Although the product has a scraper to prevent foreign matter from entering into the product, fluid containing fine foreign matter such as abrasive powder may cause sealing failure by the foreign matter adhering to the rod sliding part. Perform periodic maintenance or take countermeasures. Sealing failure of the rod sliding surface will allow reverse flow of the fluid in the pilot air piping, entering into the pilot valve or circuit connected to the pilot air piping, causing adverse effects such as operation failure or leakage.

#### 6.3 Mounting

##### Caution

Refer to Section 3.7 for mounting procedures.

#### 6.4 Replacement parts

##### Caution

- Ensure gaskets are in good condition, not deformed and are dust and debris free.
- Refer to catalogue for replacement parts.

##### Caution

- The orientation of the function plate cannot be selected.
- Changing the orientation of the function plate may cause malfunction.

#### 6.5 Storage

##### Caution

- In the case of long term storage, thoroughly remove all moisture to prevent rust and deterioration of rubber materials, etc.

### 7 Limitations of Use

##### Warning

- The failure modes of this component are not defined.
- The system designer should determine the effect of the possible failure modes of the product on the system.

#### 7.1 Limited warranty and disclaimer/compliance requirements

Refer to Handling Precautions for SMC Products.

##### Warning

#### 7.2 Effect of energy loss on valve switching

##### 7.2.1 Air operated

Air supply cut	Valve returns to OFF position by spring force
----------------	---

Table 11.

##### 7.2.2 External pilot solenoid

Pilot air supply present, electrical supply cut	Valve returns to OFF position by spring force
Electrical supply present, pilot air supply cut	Valve returns to OFF position by spring force

Table 12.

#### 7.2.3 Protection against unexpected start-up

If the external pilot valve leaks, the main unit may be activated.

#### 7.3 Low temperature operation

- The valve can be used in an ambient temperature of -5°C. However, take measures to prevent freezing or solidification of impurities, etc.
- When using valves in cold climates, take appropriate countermeasures to prevent the fluid from freezing in tubing after cutting the supply from the pump, by draining the fluid, etc. When using a heater, avoid heating the coil.
- For pilot air supply, appropriate measures should be taken to avoid solidification or freezing of drainage and moisture, etc.

### 7 Limitations of Use - continued

#### 7.4 Fluids

- The compatibility of the components of this product with the fluid used may vary depending on the type of fluid, additives, concentration, temperature, etc. Check the compatibility with the actual machine before use.
- Take measures to prevent static electricity since some fluids can cause static electricity.
- Do not use the product with the fluids listed below:
  - Fluids that are harmful to the human body.
  - Combustible or flammable fluids.
  - Corrosive gas and fluid.
  - Sea water, saline.

#### 7.5 Holding of pressure

Since valves are subject to air leakage, they cannot be used for applications such as holding pressure (including vacuum) in a system.

#### 7.6 Cannot be used as an emergency shut-off valve

This product is not designed for safety applications such as an emergency shut-off valve. If the valves are used in this type of system, other reliable safety assurance measures should be adopted.

#### 7.7 Closed circuit

In a closed circuit, when liquid is static, pressure could rise due to changes in temperature. This pressure rise could cause malfunction and damage to components such as valves. To prevent this, install a relief valve in the system.

#### 7.8 Impact by rapid pressure fluctuation

When an impact caused by the rapid pressure fluctuation, such as water hammer etc., is applied, the solenoid valve may be damaged. Install water hammer relief equipment (accumulator, etc.), or use a SMC water hammer relief valve (e.g. VXR series).

##### Caution

#### 7.9 Leakage voltage

Ensure that any leakage voltage caused by the leakage current when the switching element is OFF causes  $\leq 3\%$  (for DC coils),  $\leq 8\%$  (for AC coils with V116 pilot valve, 0.35 W type) or  $\leq 15\%$  (for AC coils with VO307 pilot valve, 1.8 W type) of the rated voltage across the valve.

#### 7.10 EMC restrictions

##### 7.10.1 Class and group description

- This product is group 1, class A equipment according to EN55011.
- Group 1 equipment does not intentionally generate radio-frequency energy in the range 9kHz to 400 GHz.
- Class A equipment is equipment suitable for use in all locations other than those allocated in residential environments and those directly connected to a low voltage power supply network which supplies buildings used for domestic purposes.
- This equipment is not intended for use in residential environments and may not provide adequate protection to radio reception in such environments.

##### 7.10.2 Cable length to connect

The cable to connect the product shall be less than or equal to 30m.

##### 7.10.3 Connecting the power supply

This product is not intended to be directly connected to any DC Distribution network.

### 8 Product Disposal

This product shall not be disposed of as municipal waste. Check your local regulations and guidelines to dispose this product correctly, in order to reduce the impact on human health and the environment.

### 9 Return of Product

If the product to be returned is contaminated or is possibly contaminated with substances that are harmful to humans, for safety reasons, please contact SMC beforehand and then employ a specialist cleaning company to decontaminate the product. After the decontamination prescribed above has been carried out, submit a Product Return Request Sheet or the Detoxification/Decontamination Certificate to SMC and await SMC's approval and further instructions before attempting to return the item. Please refer to the International Chemical Safety Cards (ICSC) for a list of harmful substances.

### 10 Contacts

Refer to [www.smcworld.com](http://www.smcworld.com) or [www.smc.eu](http://www.smc.eu) for your local distributor/importer.

## SMC Corporation

URL : <https://www.smcworld.com> (Global) <https://www.smc.eu> (Europe)  
 SMC Corporation, 4-14-1, Sotokanda, Chiyoda-ku, Tokyo 101-0021, Japan  
 Specifications are subject to change without prior notice from the manufacturer.  
 © SMC Corporation All Rights Reserved.  
 Template DKP50047-F-085N