

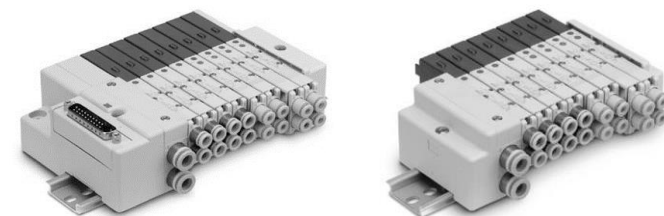

ORIGINAL INSTRUCTIONS

Instruction Manual
5 Port Solenoid Valve
Series SQ1000/2000



The intended use of this valve is to control the movement of an actuator.

1 Safety Instructions

These safety instructions are intended to prevent hazardous situations and/or equipment damage. These instructions indicate the level of potential hazard with the labels of "Caution," "Warning" or "Danger." They are all important notes for safety and must be followed in addition to International Standards (ISO/IEC)¹⁾, and other safety regulations.

- ¹⁾ ISO 4414: Pneumatic fluid power - General rules relating to systems.
- ISO 4413: Hydraulic fluid power - General rules relating to systems.
- IEC 60204-1: Safety of machinery - Electrical equipment of machines. (Part 1: General requirements)
- ISO 10218-1: Robots and robotic devices - Safety requirements for industrial robots - Part 1: Robots.

- Refer to product catalogue, Operation Manual and Handling Precautions for SMC Products for additional information.
- Keep this manual in a safe place for future reference.

Caution	Caution indicates a hazard with a low level of risk which, if not avoided, could result in minor or moderate injury.
Warning	Warning indicates a hazard with a medium level of risk which, if not avoided, could result in death or serious injury.
Danger	Danger indicates a hazard with a high level of risk which, if not avoided, will result in death or serious injury.

Warning

- Always ensure compliance with relevant safety laws and standards.
- All work must be carried out in a safe manner by a qualified person in compliance with applicable national regulations.

Caution

- The product is provided for use in manufacturing industries only. Do not use in residential premises.

2 Specifications

2.1 Valve specifications

Valve Construction	Metal Seal	Rubber Seal
Fluid	Air	
Maximum Operating Pressure	0.7 MPa (High pressure type: 1.0 MPa) ^{Note 1)}	
Minimum operating pressure	Single	0.1 MPa
	Double (double solenoid)	0.1 MPa
	3 position	0.1 MPa
	4 position	0.15 MPa
Ambient and fluid temperature	-10 to + 50 °C (no freezing) ^{Note 2)}	
Response Time	Refer to catalogue	
Flow rate	Refer to catalogue	
Pilot valve manual override	Push type / Locking type (tool required)	
Lubrication	Not required	
Vibration / Impact resistance ^{Note 3)}	30 / 150 m/s ²	
Enclosure (based on IEC60529)	IP40 equivalent	
Minimum operating frequency	1 cycle / 30 days	
Maximum operating frequency	2 position single / double	20 Hz
	4 position dual 3 port	5 Hz
	3 position	10 Hz
Mounting orientation	Refer to 7.4	

2 Specifications - continued

Duty Cycle	Contact SMC
Weight	Refer to catalogue

Table 1

- Note 1) SQ1000 metal seal type only.
 Note 2) Use dry air to prevent condensation at low temperatures.
 Note 3) **Vibration resistance:** No malfunction occurred in a one-sweep test between 45 and 2000 Hz. Test was performed at both energized and de-energized states in the axial direction and at the right angles to the main valve and armature (Values quoted are for a new valve).
Impact resistance: No malfunction occurred when it was tested with a drop tester in the axial direction and at right angles to the main valve & armature; in both energized & de-energized states and for every time in each condition (Values quoted are for a new valve).

2.2 Solenoid specifications

Valve Construction	Metal Seal	Rubber Seal
Rated coil voltage	12, 24 VDC	
Allowable voltage fluctuation ^{Note 1)}	±10% of rated voltage	
Coil insulation type	Equivalent to B type	
Power Consumption (current)	24 VDC	0.4 W (17mA), 0.95 W (40mA) ^{Note 2)}
	12 VDC	0.4 W (34 mA), 0.95 W (80 mA) ^{Note 2)}
Surge voltage suppressor	Standard, High pressure type	Diode
	Quick response type	Varistor
Indicator light	LED	

Table 2

- Note 1) Valve state is not defined if electrical input is outside of specified operating ranges.
 Note 2) Values for the quick response (0.95W), high pressure type.

2.3 LED light indication

Caution

Indicator lights are all positioned on one side for both single solenoid and double solenoid types. For double, 3 position and 4 position dual 3 port types, 2 colours are used to indicate the energization of A side or B side.

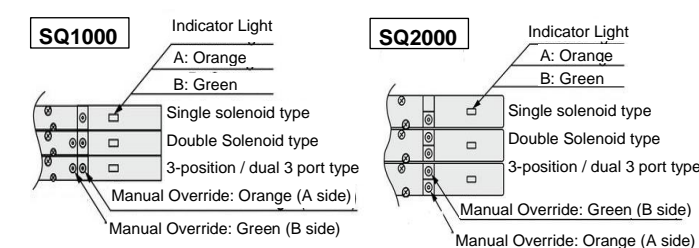

Figure 1

2.4 Pneumatic symbols

Refer to catalogue for pneumatic symbols.

2.5 Special products

Warning

Special products (-X) might have specifications different from those shown in this section. Contact SMC for specific drawings.

3 Installation

3.1 Installation

Warning

- Do not install the product unless the safety instructions have been read and understood.
- When using the double solenoid type for the first time, actuators may travel in an unexpected direction depending on the switching position of the valve. Implement measures to prevent any danger from occurring when operating the actuator.

3.2 Environment

Warning

- Do not use in an environment where corrosive gases, chemicals, saltwater or steam are present.
- Do not use in an explosive atmosphere.

3 Installation - continued

- Do not expose to direct sunlight. Use a suitable protective cover.
- Do not install in a location subject to vibration or impact in excess of the product's specifications.
- Do not mount in a location exposed to radiant heat that would result in temperatures in excess of the product's specifications.
- When the solenoid valve is mounted in a control panel or it is energized for a long time, make sure that the ambient temperature is within the specification of the valve.
- If using in an atmosphere where there is possible contact with water droplets, oil, weld spatter, etc., take suitable preventive measures.
- Do not use in high humidity environment where condensation can occur.
- Contact SMC for altitude limitations.

3.3 Piping

Caution

- Before connecting piping make sure to clean up chips, cutting oil, dust etc.
- When installing piping or fittings, ensure sealant material does not enter inside the port. When using seal tape, leave 1 thread exposed on the end of the pipe/fitting.
- Tighten fittings to the specified tightening torque.

Connection thread size (R, NPT)	Tightening Torque (N·m)
M5	1 to 1.5

Table 3

3.4 Lubrication

Caution

- SMC products have been lubricated for life at manufacture, and do not require lubrication in service.
- If a lubricant is used in the system, refer to catalogue for details.

3.5 Electrical wiring specifications

Refer catalogue for electrical wiring specifications.

3.6 Air supply

Warning

Use clean air

If the compressed air supply includes chemicals, synthetic materials (including organic solvents), salinity, corrosive gas etc., it can lead to damage or malfunction.

Caution

Install an air filter

Install an air filter upstream of the valve. Select an air filter with a filtration size of 5µm or smaller.

3.7 Effect of back pressure when using a manifold

Warning

Use caution when valves are used on a manifold, because an actuator may malfunction due to back pressure.

For 3-position exhaust centre valve or single acting cylinder, take appropriate measures to prevent malfunction by using it with an individual EXH interface block, a back pressure check valve or an individual exhaust manifold.

Also, since the SQ1000 4-position dual 3 port valves is 4 port valve specifications (5 (R1) and 3 (R2) are common), one back pressure check valve can be installed. As a result, back pressure from valves in other stations can be prevented, but back pressure inside this valve cannot be prevented.

3.8 Indicator light/surge voltage suppressor

Single solenoid type (SQ1000/2000)

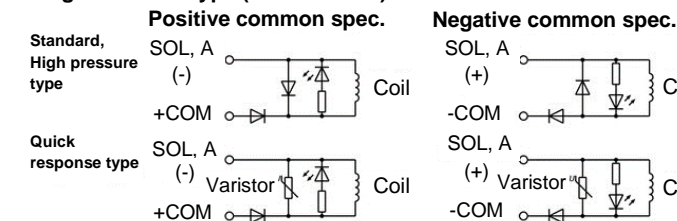

Figure 2

3 Installation - continued

Double solenoid type (SQ1000/2000)

3 position type (SQ1000/2000)

4 position dual 3 port type (SQ1000/2000)

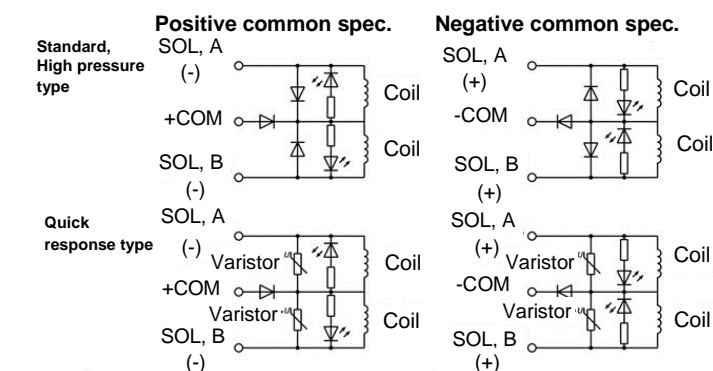

Figure 3

3.9 Residual voltage of the surge voltage suppressor

Caution

If a Zener diode or varistor voltage suppressor is used, the suppressor arrests the back EMF voltage from the coil to the level indicated in Table 4.

Ensure the transient voltage is within the specification of the host controller.

Valve response time is dependent on surge suppression method selected.

Series	Type	Residual Voltage
SQ1000 / 2000	Standard type	Approx. 1 V
	Quick response type	Approx. -40 V

Table 4

3.10 Extended periods of continuous energization

Warning

If a valve is energized continuously for a long period of time, the rise in temperature due to heat rise of the coil assembly may cause a decline in solenoid valve performance, reduce service life, or have adverse effects on peripheral equipment. If the valve is energized continuously for a long period of time, be sure to use the standard type (0.4 W) at an ambient temperature of 40°C or less, and make sure to radiate heat sufficiently.

In particular, if three or more adjacent stations on the manifold are energized simultaneously for extended periods of time or if the valves on A side and B side are energized simultaneously for a long period of time, take special care as the temperature rise will be greater.

3.11 Manual override

Warning

Regardless of an electric signal for the valve, the manual override is used for switching the main valve. Connected actuator is started by manual operation. Only use the manual override after confirming that there is no danger.

Locked manual overrides might prevent the valve responding to being electrically de-energized or cause unexpected movement in the equipment.

Refer to the catalogue for details of manual override operation.

3.12 Back pressure check valve

Caution

Back pressure from the common manifold exhausts can be prevented from affecting actuators connected to ports 2 and 4 by fitting check valves (SSQ1000-BP or SSQ2000-BP). As slight air leakage is allowed for the back pressure, take care the exhaust air will not be restricted at the exhaust port. The flow capacity of the valve is reduced in these cases. Refer catalogue for full details on back pressure check valves.

3 Installation - continued

3.13 External pilot exhaust

Caution

The external pilot variants use the manifold PE connection for pilot exhaust. Ensure that this connection is always vented to atmosphere and not subject to any pressure pulses from other devices.

3.14 Mounting and removal of valves and manifold

Refer to section 6.2 for details.

4 How to Order

4.1 Standard products

Refer to catalogue for 'How to order' information.

4.2 Special products

For special products (-X number) refer to product drawing for 'How to order' details and specifications.

5 Outline Dimensions

Refer to the catalogue for outline dimensions.

6 Maintenance

6.1 General maintenance

Refer to specifications

Caution

- Not following proper maintenance procedures could cause the product to malfunction and lead to equipment damage.
- If handled improperly, compressed air can be dangerous.
- Maintenance of pneumatic systems should be performed only by qualified personnel.
- Before performing maintenance, turn off the power supply and be sure to cut off the supply pressure. Confirm that the air is released to atmosphere.
- After installation and maintenance, apply operating pressure and power to the equipment and perform appropriate functional and leakage tests to make sure the equipment is installed correctly.
- If any electrical connections are disturbed during maintenance, ensure

they are reconnected correctly, and safety checks are carried out as required to ensure continued compliance with applicable national regulations.

- Do not make any modification to the product.
- Do not disassemble the product, unless required by installation or maintenance instructions.
- When the 3-position closed centre type is in its rest position, air can be trapped between the valve and the cylinder. Exhaust this air pressure before removing piping or performing any maintenance.
- When the equipment is operated after remounting or replacement, first confirm that measures are in place to prevent unexpected movement of actuators, etc. Then, confirm that the equipment is operating normally.

6.2 Removal and mounting of valves and manifold

Caution

6.2.1 Removal and mounting of valves

Refer to the Specific Product Precautions in the catalogue for details of mounting and removal of valves from manifold.

Ensure gaskets are in good condition, not deformed and are dust and debris free.

When mounting valves ensure gaskets are present, aligned and securely in place and tighten the valve mounting screw to the appropriate tightening torque.

Model	Tightening torque (N-m)
SQ1000	0.17 to 0.23
SQ2000	0.25 to 0.35

Table 5

6.2.2 Removal and mounting of manifold with DIN rail

Refer to the Specific Product Precautions in the catalogue for details of mounting and removal of manifold from DIN rail.

The tightening torque of the clamping screw is 0.8 to 1.0 N-m.

6.3 Increase manifold stations

Refer to catalogue for details on how to increase connector type manifold stations.

6 Maintenance - continued

Caution

Make sure the clamping screw is tightened to the correct torque (0.8 to 1.0 N·m).

6.4 Replacing cylinder port fitting

Cylinder port fittings are available in cassette type and can be replaced easily. Fittings are secured with a clip that is inserted from the top side of the valve. Remove the clip with a flat head screwdriver, etc., to replace the fittings. To mount a fitting, insert the fitting assembly until it stops and reinsert the clip into its designated position.

Caution

Do not scratch or put foreign matter on the O-rings as this will cause air leakage.

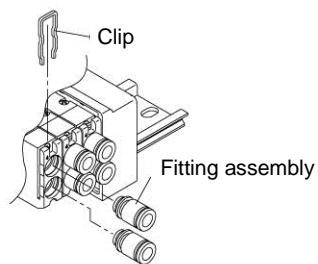

Figure 4

6.5 Replacing built-in silencer element

Caution

A filter element is built into the manifold base end plate. When the element becomes dirty and clogged, this will cause trouble such as a drop in the cylinder speed, etc. Therefore, replace the element regularly.

Refer to catalogue for additional information.

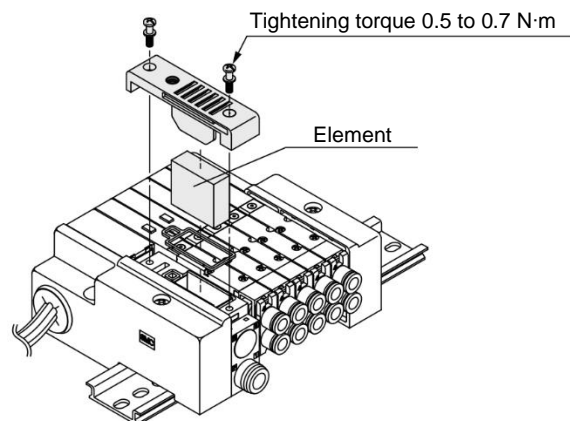

Figure 5.

7 Limitations of Use

Warning

The system designer should determine the effect of the possible failure modes of the product on the system.

7.1 Limited warranty and disclaimer/compliance requirements

Refer to Handling Precautions for SMC Products.

Caution

7.2 Leakage voltage

Ensure that any leakage voltage caused by the leakage current when the switching element is OFF is $\leq 3\%$ or less of the rated voltage across the valve.

7.3 Low temperature operation

Unless otherwise indicated in the specifications for each valve, operation is possible to -10°C , but appropriate measures should be taken to avoid solidification or freezing of drainage and moisture, etc.

7 Limitations of Use - continued

7.4 Mounting orientation

7.4.1 Rubber seal

Universal

7.4.2 Metal seal

Mounting orientation of a single solenoid is universal. No specific orientation is necessary.

When installing a double solenoid or a 3-position configuration, mount the main valve so that valve spool is horizontal. See catalogue for valve cross sections.

Warning

7.5 Intermediate stopping

Refer to Handling Precautions for 3/4/5 port Solenoid Valves.

7.6 Holding of pressure (including vacuum)

Since valves are subject to air leakage, they cannot be used for applications such as holding pressure (including vacuum) in a pressure vessel.

7.7 Cannot be used as an emergency shut-off valve

This product is not designed for safety applications such as an emergency shut-off valve. If the valves are used in this type of system, other reliable safety assurance measures should be adopted.

7.8 Momentary energization/operation

Caution

If a double solenoid valve is operated with momentary energization, it should be energized for at least 0.1 second. However, depending on the secondary load conditions, it should be energized until the cylinder reaches the stroke end position, as there is a possibility of malfunction otherwise.

7.9 Air returned or air/spring returned spool valves

Warning

The use of 2-position single valves with air returned or air/spring returned spools has to be carefully considered.

The return of the valve spool into the de-energized position depends on the pilot pressure. If the pilot pressure drops below the specified operating pressure the position of the spool cannot be defined. The design of the system must take into account such behaviour.

Additional measures might be necessary. For example, the installation of an additional air tank to maintain the pilot pressure.

Energy source status	Single	Double	3 position	Dual 3 Port
Air supply present, electricity cut	Spool returns to the off position by air force and spring force	Spool stops moving after electricity cut (Position cannot be defined)	Spool returns to the off position by spring force	Spools return to the off position by air force and spring force
Air supply cut before electricity cut	Spool returns to the off position by spring force	Spool stops moving after air pressure cut (Position cannot be defined)	Spool returns to the off position by spring force	Spools return to the off position by spring force

Table 6.

7.10 Safety relays

Warning

If a safe output from a safety relay or PLC is used to operate this valve, ensure that any output test pulse duration is shorter than 1 ms to avoid the valve solenoid responding.

8 Product Disposal

This product shall not be disposed of as municipal waste. Check your local regulations and guidelines to dispose this product correctly, in order to reduce the impact on human health and the environment.

9 Contacts

Refer to www.smcworld.com or www.smc.eu for your local distributor/importer.

SMC Corporation

URL: <https://www.smcworld.com> (Global) <https://www.smc.eu> (Europe)
 SMC Corporation, 4-14-1, Sotokanda, Chiyoda-ku, Tokyo 101-0021, Japan
 Specifications are subject to change without prior notice from the manufacturer.
 © 2021 SMC Corporation All Rights Reserved.
 Template DKP50047-F-0851