



ORIGINAL INSTRUCTIONS

**Instruction Manual**  
**2 port valve for flow control**  
**Series VNB**



The intended use of this valve is to control the air in the downstream pneumatic circuit..

**1 Safety Instructions**

These safety instructions are intended to prevent hazardous situations and/or equipment damage. These instructions indicate the level of potential hazard with the labels of "Caution," "Warning" or "Danger." They are all important notes for safety and must be followed in addition to International Standards (ISO/IEC)<sup>(1)</sup>, and other safety regulations.

<sup>(1)</sup>ISO 4414: Pneumatic fluid power - General rules and safety requirements for systems and their components.

ISO 4413: Hydraulic fluid power - General rules and safety requirements for systems and their components.

IEC 60204-1: Safety of machinery - Electrical equipment of machines. Part 1: General requirements

ISO 10218-1: Robots and robotic devices - Safety requirements for industrial robots - Part 1: Robots

- Refer to product catalogue, Operation Manual and Handling Precautions for SMC Products for additional information.
- Keep this manual in a safe place for future reference.

<b>Danger</b>	Danger indicates a hazard with a high level of risk which, if not avoided, will result in death or serious injury.
<b>Warning</b>	Warning indicates a hazard with a medium level of risk which, if not avoided, could result in death or serious injury.
<b>Caution</b>	Caution indicates a hazard with a low level of risk which, if not avoided, could result in minor or moderate injury.

**Warning**

- Always ensure compliance with relevant safety laws and standards.
- All work must be carried out in a safe manner by a qualified person in compliance with applicable national regulations.
- If this equipment is used in a manner not specified by the manufacturer, the protection provided by the equipment may be impaired.

**Caution**

- The product is provided for use in manufacturing industries only. This product must not be used in residential areas.

**2 Specifications**

**2.1 Valve specifications**

Fluid	Water, Oil, Air, Vacuum, etc. (Refer to Table 6)	
Applicable pressure range [MPa] <sup>Note 1)</sup>	VNB##1#	Low vacuum to 0.5
	VNB##3#	Low vacuum to 1
Ambient temperature [°C]	-5 to 50 <sup>Note 1)</sup> (Air operated type:60)	
Fluid temperature [°C]	VNB###A, VNB#1# <sup>B</sup> <sub>C</sub>	-5 to 60 (no freezing)
	VNB#0# <sup>B</sup> <sub>C</sub>	-5 to 99 (no freezing) (Water, Oil etc. Air operated only)
Min. operating frequency	1 cycle / 30 days	
Max. operating frequency	Contact SMC	
Flow characteristics	Refer to catalogue	
Response time [ms]	Contact SMC	
Duty cycle	Contact SMC	

**2 Specifications – continued**

External pilot air	Pressure [MPa]	VNB##1#	0.25 to 0.7
		VNB##2#	0.1 + 0.25 x (Operating pressure) to 0.25 + 0.25 x (Operating pressure) (Refer to Figure 1) <sup>Note 2)</sup>
	Lubrication	Not required <sup>Note 3)</sup>	
	Temperature [°C]	-5 to 50 (Air operated type: 60)	
Lubrication	Not required		
Impact/Vibration resistance [m/s <sup>2</sup> ] <sup>Note 4)</sup>	150/30		
Enclosure (based on IEC60529)	IP50		
Mounting orientation	Restricted <sup>Note 5)</sup>		
Wetted parts	Refer to table 6		
Weight	Refer to catalogue		

Table 1.

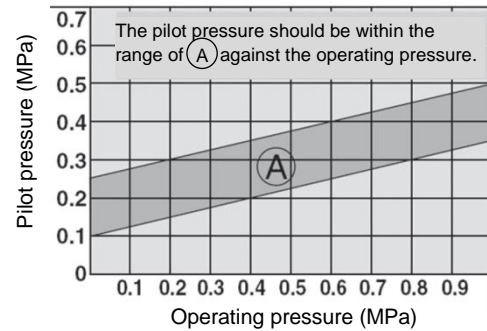

Figure 1.

Note 1) The pressure differential between Port 1 (A) and 2 (B) must not exceed the maximum operating pressure.

Note 2) Adjust the operating pressure range from 0.125 MPa to 0.275 MPa for low vacuum.

Note 3) Lubrication is not allowed in the case of seal material EPDM.

Note 4) Impact resistance: No malfunction occurred when it was tested with a drop tester in the axial direction and at right angles to the main valve and armature; in both energized and de-energised states and for every time in each condition. (Values quoted are for a new valve).

Vibration resistance: No malfunction occurred in a one-sweep test between 45 and 2000 Hz. Tests are performed at both energized and de-energized states in the axial direction and at right angles to the main valve and armature. (Values quoted are for a new valve).

Note 5) To prevent foreign matter from entering the plate assembly part, the valve should not be mounted downwards.

**2.2 Vacuum pilot type**

Fluid	Vacuum
Operating pressure range	-101 kPa to Atmospheric pressure
Pilot pressure range [kPa]	-101 to -47.9

Table 2.

Note) It is used when the valve is to be operated by the main vacuum in the absence of pressurized air.

**2.3 Solenoid specifications**

Port size	6A to 25A		32A to 50A	
Pilot valve	SF4-□ <sup>D</sup> <sub>DZ</sub> -23-Q		VO307-□ <sup>D</sup> <sub>DZ</sub> 1-Q	
Coil rated voltage	DC [VDC]	24 (semi-standard: 12)		
	AC [VAC]	100, 200 (semi-standard: 110, 220, 240)		
Electrical entry	DIN terminal			
Coil insulation class	Class B			
Allowable voltage fluctuation <sup>Note 1)</sup>	-15 % to +10 % of rated voltage <sup>Note 1)</sup>			
Temperature rise [°C]	35 or less (when rated voltage is applied)		50 or less (when rated voltage is applied)	
	Apparent power [VA]	Inrush	5.6 (50 Hz), 5.0 (60 Hz)	12.7 (50 Hz), 10.7 (60 Hz)
Holding		3.4 (50 Hz), 2.3 (60 Hz)	7.6 (50 Hz), 5.4 (60 Hz)	
Power consumption [W]	1.8 (without light), 2 (with light)		4 (without light), 4.2 (with light)	
Manual override	Non-locking push type Other (semi-standard)		Non-locking push type	
Surge voltage suppressor	AC	Varistor		
	DC	Diode		

Table 3.

**2 Specifications – continued**

Note 1) Valve state is not defined if electrical input is outside of specified operating ranges.

Note 2) For "How to Order" pilot solenoid valves, refer to the catalogue.

Note 3) Vacuum pilot type pilot solenoid valves will become VO307V-□<sup>D</sup><sub>DZ</sub>1-Q.

**2.4 Port size**

Model	Port size Rc	Orifice dia. Ø [mm]
VNB1□□□-6A	1/8	7
VNB1□□□-8A	1/4	
VNB1□□□-10A	3/8	
VNB2□4□-10A	3/8	11
VNB2□□□-10A		15
VNB2□4□-15A		11
VNB2□□□-15A	1/2	15
VNB3□4□-20A		14
VNB3□□□-20A	3/4	20

Model	Port size		Orifice dia. Ø [mm]
	Rc	Flange <sup>1)</sup>	
VNB4□4□-25A	1	-	16
VNB4□□□-25A	-	-	25
VNB5□4□-32A	1 1/4	-	22
VNB5□□□-32A		-	32
VNB5□4□-32F	-	32	22
VNB5□□□-32F	-	32	32
VNB6□4□-40A	1 1/2	-	28
VNB6□□□-40A		-	40
VNB6□4□-40F	-	40	28
VNB6□□□-40F	-	40	40
VNB7□4□-50A	2	-	33
VNB7□□□-50A		-	50
VNB7□4□-50F	-	50	33
VNB7□□□-50F	-	50	50

Table 4.

Note 1) Refer to catalogue for details of pneumatic symbols.

**2.5 Pneumatic symbol**

Refer to catalogue for details of pneumatic symbols.

**2.6 Special products**

**Warning**

Special products (-X) might have specifications different from those shown in this section. Contact SMC for specific drawings.

**2.7 Applicable fluids check list**

Wetted part Body material	Copper alloy: Standard			Aluminium: L			Stainless steel: S		
	NBR:A	FKM:B	EPDM:C	NBR:A	FKM:B	EPDM:C	NBR:A	FKM:B	EPDM:C
Wetted part Seal									
Fluid									
Air (Standard, Dry)	•	•	-	•	•	-	•	•	-
Low vacuum (Up to -101 kPa)	•	•	-	•	•	-	•	•	-
Carbon dioxide (CO <sub>2</sub> , 0.7 MPa or less)	•	-	-	•	-	-	•	-	-
Carbon dioxide (CO <sub>2</sub> , 0.7 to 1 MPa)	-	-	•	-	-	•	-	-	•
Nitrogen gas (N <sub>2</sub> )	•	•	•	•	•	•	•	•	•
Argon	•	•	-	•	•	-	•	•	-
Helium	-	•	-	-	•	-	-	•	-
Water (standard, up to 60 °C)	•	-	-	-	-	-	•	-	-
Water (operated up to 99 °C air operated type only)	-	•	•	-	-	-	-	•	•
Turbine oil	•	•	-	•	•	-	•	•	-
Spindle oil	-	•	-	-	•	-	-	•	-
Fuel oil Class 3 (C fuel oil)	-	•	-	-	•	-	-	•	-
Silicone oil	-	•	-	-	-	-	-	•	-
Naphtha	-	•	-	-	-	-	-	•	-
Ethylene glycol (up to 80 °C)	-	-	•	-	-	-	-	-	•
Boiler water	-	-	-	-	-	-	•	-	•

Table 6.

**3 Installation**

**3.1 Installation**

**Warning**

- Do not install the product unless the safety instructions have been read and understood.
- Some products in this series are heavy (up to 11.5 kg), take adequate measures when handling and installing it.

**3.2 Environment**

**Warning**

- Do not use in an environment where corrosive gases, chemicals, salt water or steam are present.
- Do not use in an explosive atmosphere.
- Do not expose to direct sunlight. Use a suitable protective cover.
- Do not install in a location subject to vibration or impact in excess of the product's specifications.
- Do not mount in a location exposed to radiant heat that would result in temperatures in excess of the product's specifications.
- If this valve is exposed to water or oil droplets, ensure it is protected.
- Products compliant with IP50 have limited protection against dust.
- Products compliant with IP50 enclosures satisfy the specifications by mounting each product properly. Be sure to read the Specific Product Precautions for each product.
- Do not use in high humidity environment where condensation can occur.
- Altitude limitation is 1000 m above sea level.

**3.3 Piping**

**Caution**

- Before connecting piping make sure to clean up chips, cutting oil, dust etc.
- When installing piping or fittings, ensure sealant material does not enter inside the port. When using seal tape, leave 1.5 to 2 thread exposed on the end of the pipe/fitting.
- Tighten fittings to the specified tightening torque.

Thread	Tightening torque [N·m]
1/8	7 to 9
1/4	12 to 14
3/8	22 to 24
1/2	28 to 30
3/4	28 to 30
1	36 to 38
1 1/4	40 to 42
1 1/2	48 to 50
2	48 to 50

Table 7.

**3.3.1 Pilot ports P1 and P2**

**Caution**

- Pilot port piping 12(P1) and 10(P2) piping should be as follows according to the model.

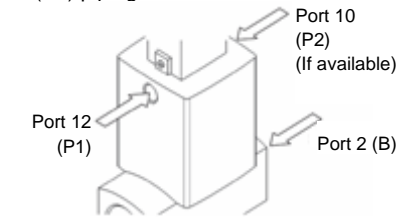

Figure 2.

Standard	VNB□0(1,4)□	VNB□02□	VNB□03□	VNB□1(1,2,4)□
12 (P1)	External pilot	Bleed port	External pilot*	External pilot
10 (P2)	Bleed port	External pilot	External pilot*	Pilot exhaust

\*If the pilot air is not supplied, the valve position will not be held. Pressurize Port 12(P1) or Port 10(P2) when using product.

Table 8.

Vacuum pilot	VNB□01V□	VNB□02V□	VNB□1(1,2)V□
12 (P1)	Bleed port	External pilot	External pilot
10 (P2)	External pilot	Bleed port	Pilot exhaust

Table 9.

### 3 Installation - continued

- Installing a silencer to either the exhaust port or the bleed port is recommended for noise reduction and for dust entry prevention.

#### 3.3.2 Vacuum pilot

- When using the VNB□01□V vacuum pilot, maintain the specified pilot pressure by providing a tank with an appropriate capacity or by acquiring the pilot pressure from an area near the vacuum pump.

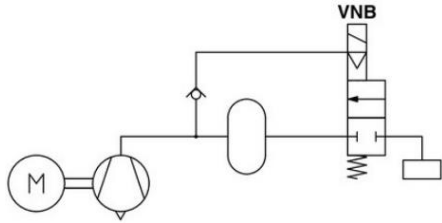

Figure 3.

#### 3.4 Lubrication

##### Warning

- SMC products have been lubricated for life at manufacture, and do not require lubrication in service.
- If a lubricant is used in the system, refer to catalogue for details.

#### 3.5 Fluid supply

##### Warning

- The use of a fluid that contains foreign matter can cause problems, such as malfunction and seal failure by promoting the wear of the valve seat and armature, by sticking to the sliding parts of the armature, etc.
- Install a suitable filter (strainer) immediately upstream of the valve.
- Select a filter with a filtration size of 5 µm or smaller for air, and 100 mesh for water.
- Fluid containing fine foreign matter such as abrasive powder may cause sealing failure by the foreign matter adhering to the rod sliding part. Perform periodic maintenance or take countermeasures. Sealing failure of the rod sliding surface will allow reverse flow of the fluid into the pilot air piping, entering the pilot valve or circuit connected to the pilot air piping, causing adverse effects such as operation failure or leakage.

#### 3.5.1 Air

##### Warning

- Use clean air. If the compressed air supply includes chemicals, synthetic materials (including organic solvents), salinity, corrosive gas etc., it can lead to damage or malfunction.

##### Caution

- Compressed air that includes excessive drainage may cause malfunction of valves and other pneumatic equipment. To prevent this, install an air dryer or after cooler, etc.
- If excessive carbon powder is generated by the compressor, it may adhere to the inside of the valves and cause a malfunction. Install mist separators upstream of the valves to eliminate it.
- When operating fluid air with a dew point of -70°C or lower, the inside of the valve may wear and the product life will be shortened.

#### 3.5.2 Water

##### Warning

- Be aware that rust stains, chloride separation, etc., from the piping may cause malfunction, leakage, or, in worse case scenarios, damage due to corrosion. Also, such damage may result in the spraying of fluids or scattering of parts. Please be sure to have protective measures in place in case such incidents should occur.
- In the case that water contains substances such as calcium and magnesium, which generate hard scale and sludge, install water softening equipment and a filter (strainer) directly upstream from the valve to remove these substances, as this scale and sludge can cause the valve to malfunction.
- The water pressure of tap water is usually 0.4 MPa or less, but the pressure can sometimes increase to 1.0 MPa in tall buildings. Therefore, pay attention to the max. operating pressure differential.

#### 3.5.3 Oil

##### Warning

- Generally, FKM is used as seal material, as it is resistant to oil. However, the resistance of the seal material may deteriorate depending on the type of oil, manufacturer, or additives. Check the resistance before using.
- The kinematic viscosity of fluid must not exceed 500 mm<sup>2</sup>/s.

### 3 Installation - continued

#### 3.5.4 Steam

##### Warning

- Do not use steam that contains chemicals, synthetic oils containing organic solvents, salts or corrosive gases etc., as these can cause damage or deterioration.

#### 3.6 Manual override

##### Warning

- Manual override is used to switch the main valve without inputting an electrical signal for the valve. When manual operation is performed, the connected actuator will start operating, so be sure to confirm that it is safe to operate beforehand.
- Locked manual overrides might prevent the valve responding to being electrically de-energised or cause unexpected movement in the equipment.

#### 3.6.1 Non-locking push type

- VNB1-4** Push on the manual override button using a small bladed screwdriver until it stops ON. Hold this position for the duration of the check (ON position). Release the button and the override will re-set to OFF position.
- VNB5-7** No tool needed.

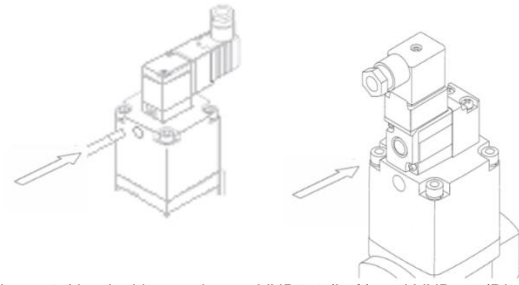

Figure 4. Non-locking push type VNB1-4 (Left) and VNB5-7 (Right)

#### 3.6.2 Push-locking slotted type

- To lock  
Using a small-bladed screwdriver in the slot, push the manual override button until it stops. Turn the override button 90° in the direction of the

arrow until it stops (ON position).  
Remove the screwdriver.

##### Warning

In this position the manual override is in the locked 'ON' position.

- To unlock  
Place a small-bladed screwdriver in the slot and push the manual override button. Turn the override button 90° in the reverse direction of the arrow. Remove the screwdriver and the manual override will re-set to the OFF position.

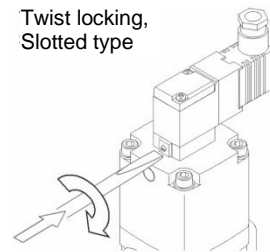

Figure 5. Push locking slotted type

#### 3.7 Mounting

##### Warning

Do not install with the coil downwards. If a valve is mounted with the coil positioned downwards, foreign objects in the fluid will adhere to the core/armature leading to a malfunction.

##### Caution

- Ensure gaskets are in good condition, not deformed and are dust and debris free.
- Do not apply external force to the coil section.**  
When tightening is performed, apply a wrench or other tool to the outside of the piping connection parts.
- Mount a valve with its coil position upwards, not downwards.**  
When mounting a valve with its coil positioned downwards, foreign objects in the fluid will adhere to the iron core leading to malfunction. Especially for strict leakage control, such as with vacuum applications and non-leak specifications, the coil must be positioned upwards.

### 3 Installation - continued

#### 3.7.1 Bracket (optional)

- Valve series 1, 2, 3 and 4 can be mounted using a bracket.
- When mounting valves ensure gaskets are present, aligned and securely in place and tighten mounting screws to a torque as per the table below:

Thread	Appropriate tightening torque [N·m]
M4	1.5
M5	3.0
M6	5.2

Table 10.

Refer to catalogue for additional information.

#### 3.8 Electrical circuits

##### Caution

Surge suppression should be specified by using the appropriate part number. If a valve type without suppression (Type G, E, T, or D) is used, suppression must be provided by the host controller as close as possible to the valve.

#### 3.8.1 VNB1 to 4 (Valve size 1 to 4)

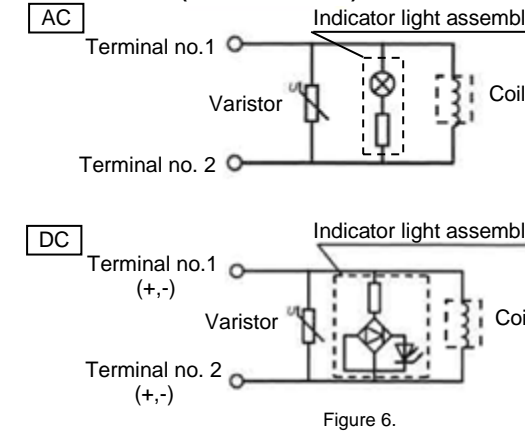

Figure 6.

#### 3.8.2 VNB5 to 7 (Valve size 5 to 7), Vacuum pilot type (Valve size 2 to 7)

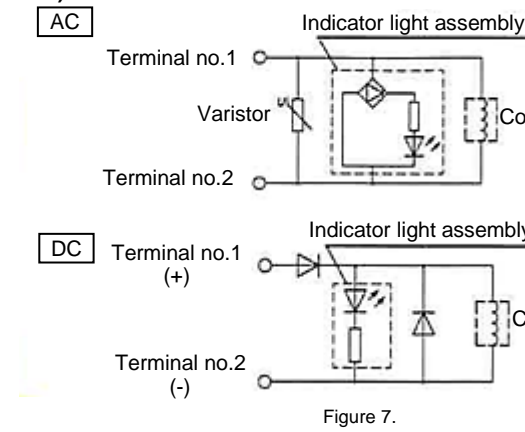

Figure 7.

#### 3.9 Electrical connectors

- When electrical power is connected to a solenoid valve, be careful to apply the proper voltage. Improper voltage may cause malfunction or coil damage.
- After completing the wiring, confirm that the connections are correct.
- When DC power is connected to a solenoid valve equipped with light and/or surge voltage suppressor, check for polarity indications.
- For polarity indications:  
Valve sizes 5 to 7 have diodes to protect polarity: If the polarity connection is wrong then the valve will not switch. In addition to this, damage could be caused in the diode in the valve, the switching device at the control equipment or, the power supply.

### 3 Installation - continued

#### 3.9.1 DIN connector

Refer to catalogue of pilot solenoid valve for additional details.

##### Warning

The ground terminal is connected to the coil assembly only and does not provide a protective earth for the body of the valve.

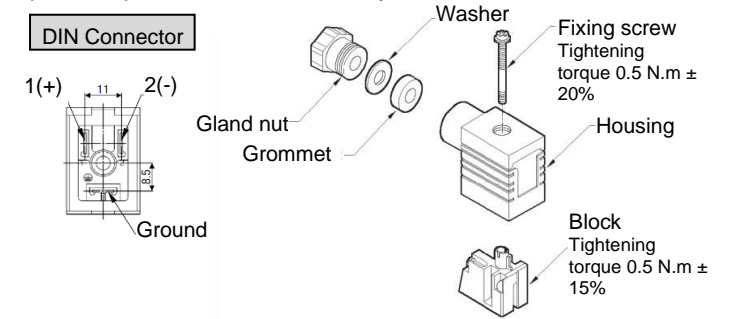

Figure 8

#### 3.10 Residual voltage

##### Caution

- If a Zener diode or varistor voltage suppressor is used, the suppressor arrests the back EMF voltage from the coil to a level in proportion to the rated voltage.
- Ensure the transient voltage is within the specification of the host controller.
- In the case of a diode, the residual voltage is approximately 1 V.
- Valve response time is dependent on surge suppression method selected.

#### 3.11 Countermeasure for surge voltage

##### Caution

- At times of sudden interruption of the power supply, the energy stored in a large inductive device may cause non-polar type valves in a de-energised state to switch.
- When installing a breaker circuit to isolate the power, consider a valve with polarity (with polarity protection diode), or install a surge absorption diode across the output of the breaker.

#### 3.12 Extended period of continuous energization

##### Warning

- If a valve is continuously energized for an extended period of time, the temperature of the valve will increase due to the heat generated by the coil. This will likely adversely affect the performance of the solenoid valve and any nearby peripheral equipment. Should a valve be continuously energized for an extended period of time or its daily energized state exceeds its non-energized state, please use an energy saving type valve with DC specification. If an AC type is expected to be energized continuously for long periods of time, select the air-operated valve and use the continuous duty type of the VT307 for a pilot valve.

### 4 How to Order

Refer to catalogue for 'How to Order' or to product drawing for special products.

### 5 Outline Dimensions

Refer to catalogue for outline dimensions.

### 6 Maintenance

#### 6.1 General maintenance

##### Caution

- Not following proper maintenance procedures could cause the product to malfunction and lead to equipment damage.
- If handled improperly, compressed air can be dangerous.
- Maintenance of pneumatic systems should be performed only by qualified personnel.
- Before performing maintenance, turn off the power supply and be sure to cut off the supply pressure. Confirm that the air is released to atmosphere.
- After installation and maintenance, apply operating pressure and power to the equipment and perform appropriate functional and leakage tests to make sure the equipment is installed correctly.

## 6 Maintenance – continued

- If any electrical connections are disturbed during maintenance, ensure they are reconnected correctly and safety checks are carried out as required to ensure continued compliance with applicable national regulations.
- Do not make any modification to the product.
- Do not disassemble the product, unless required by installation or maintenance instructions.

### 6.2 Vacuum pilot

When using VNB□<sup>0</sup><sub>1</sub>V N.C. vacuum pilot, maintain the specified pilot pressure by providing a tank with an appropriate capacity or by acquiring the pilot pressure from an area near the vacuum pump.

### 6.3 Filters and strainers

- Be careful regarding clogging of filters and strainers.
- Replace filter elements after one year of use, or earlier, if the pressure drop reaches 0.1 MPa
- Clean strainers when the pressure drop reaches 0.1 MPa.

### 6.4 Storage

In case of long term storage after use with heated water, thoroughly remove all moisture to prevent corrosion, and deterioration of rubber materials etc.

### 6.5 Drain flushing

Remove drainage from air filters regularly. (Refer to the specifications)

### 6.6 Replacement parts

#### 6.6.1 Replacing plate assembly and valve element (see Figure 9)

1. Remove body mounting screws.
2. Apply sufficient air pressure to pilot port to release plate assembly.
3. Place well-fitting slotted screwdriver into slot in piston rod and unscrew seal mounting nut with spanner.
4. If spring pin is used, slide pin out and remove valve element.
5. Slide off valve element, washers and plate assembly.
6. Refitting is reverse of removal (use correct tightening torque).

#### 6.6.2 Replacing Pilot Valve Assembly (see Figure 9)

1. Remove pilot valve mounting screws.
2. Remove pilot valve (retain DIN plug if necessary).
3. Fitting of new pilot valve is reverse of removal assembly (use correct tightening torque).

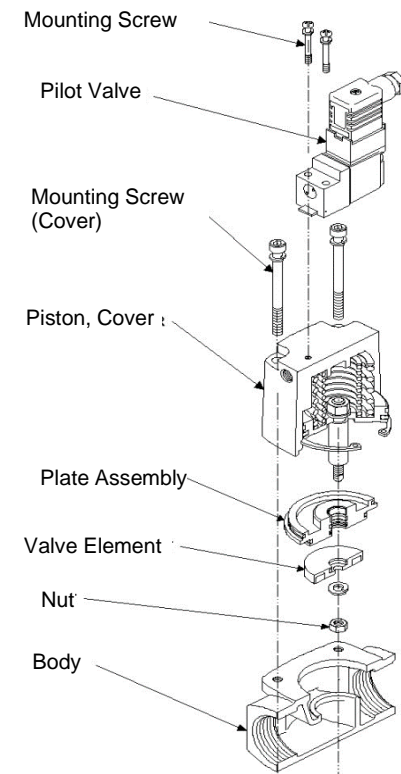

Figure 9.

## 6 Maintenance – continued

### ⚠ Caution

- Never remove inner circlip from valve.
- When replacing external pilot valve, ensure it is mounted in the correct direction. If mounted in the wrong direction, it may malfunction or leak air.

#### Tightening torque [N·m]

Valve size	VNB1	VNB2	VNB3	VNB4	VNB5	VNB6	VNB7
Seal mounting nut	–	1.5	3	3	5.2	12.5	24.5
Piston cover mounting screw	1.5	1.5	3	5.2	5.2	12.5	12.5
Pilot valve mounting screw	0.63	0.63	0.63	0.63	1.5	1.5	1.5

Table 11.

### 6.7 Storage

### ⚠ Caution

In the case of long term storage, thoroughly remove all moisture to prevent rust and deterioration of rubber materials, etc.

## 7 Limitations of Use

### ⚠ Warning

The system designer should determine the effect of the possible failure modes of the product on the system.

### 7.1 Limited warranty and disclaimer/compliance requirements

Refer to Handling Precautions for SMC Products.

### ⚠ Warning

#### 7.2 Effect of energy loss on valve switching

N.C / N.O.	
Air supply present, electrical supply cut	Valve moves to the de-energised position by spring return.
Electrical supply present, air supply cut	Valve remains in the energised position.

C.O.	
Air supply cut	Valve stops moving, position cannot be defined.

Table 12.

### 7.3 Low temperature operation

- The valve can be used in an ambient temperature of between -5 to -20°C. However, take measures to prevent freezing or solidification of impurities, etc.
- When using valves for water application in cold climates, take appropriate countermeasures to prevent the water from freezing in tubing after cutting the water supply from the pump, by draining the water, etc. When warming by a heater, etc., be careful not to expose the coil portion to a heater. Installation of a dryer, heat retaining of the body is recommended to prevent freezing condition in which the dew point temperature is high and the ambient temperature is low, and the high flow runs.

### ⚠ Warning

### 7.4 Fluids

- The compatibility of the components of this product with the fluid used may vary depending on the type of fluid, additives, concentration, temperature, etc. Check the compatibility with the actual machine before use.
- Take measures to prevent static electricity since some fluids can cause static electricity.
- Do not use the product with the fluids listed below:
  - Fluids that are harmful to the human body.
  - Combustible or flammable fluids.
  - Corrosive gas and fluid.
  - Sea water, saline.

### 7.5 Holding of pressure

Since valves are subject to air leakage, they cannot be used for applications such as holding pressure (including vacuum) in a system.

## 7 Limitations of Use – continued

### 7.6 Cannot be used as an emergency shut-off valve

This product is not designed for safety applications such as an emergency shut-off valve. If the valves are used in this type of system, other reliable safety assurance measures should be adopted.

### 7.7 Closed circuit

In a closed circuit, when liquid is static, pressure could rise due to changes in temperature. This pressure rise could cause malfunction and damage to components such as valves. To prevent this, install a relief valve in the system.

### 7.8 Impact by rapid pressure fluctuation

When an impact caused by the rapid pressure fluctuation, such as water hammer etc., is applied, the solenoid valve may be damaged. Install water hammer relief equipment (accumulator, etc.), or use a SMC water hammer relief valve (e.g. VXR series).

### 7.9 Safety relays or PLC

If a safe output from a safety relay or PLC is used to operate this valve, ensure that any output test pulse duration is shorter than 1 ms to avoid the valve solenoid responding.

### ⚠ Caution

### 7.10 Leakage voltage

Ensure that any leakage voltage caused by the leakage current when the switching element is OFF causes ≤ 3% (for DC coils) or ≤ 15% (for AC coils) of the rated voltage across the valve.

### 7.11 EMC restrictions

#### 7.11.1 Class and group description

- This product is group 1, class A equipment according to EN55011.
- Group 1 equipment does not intentionally generate radio-frequency energy in the range 9kHz to 400 GHz.
- Class A equipment is equipment suitable for use in all locations other than those allocated in residential environments and those directly connected to a low voltage power supply network which supplies buildings used for domestic purposes.
- This equipment is not intended for use in residential environments and may not provide adequate protection to radio reception in such environments.

#### 7.11.2 Cable length to connect

The cable to connect the product shall be less than or equal to 30m.

#### 7.11.3 Connecting the power supply

This product is not intended to be directly connected to any DC Distribution network.

## 8 Product Disposal

This product shall not be disposed of as municipal waste. Check your local regulations and guidelines to dispose this product correctly, in order to reduce the impact on human health and the environment.

## 9 Return of Product

If the product to be returned is contaminated or is possibly contaminated with substances that are harmful to humans, for safety reasons, please contact SMC beforehand and then employ a specialist cleaning company to decontaminate the product. After the decontamination prescribed above has been carried out, submit a Product Return Request Sheet or the Detoxification/Decontamination Certificate to SMC and await SMC's approval and further instructions before attempting to return the item. Please refer to the International Chemical Safety Cards (ICSC) for a list of harmful substances.

## 10 Contacts

Refer to [www.smcworld.com](http://www.smcworld.com) or [www.smc.eu](http://www.smc.eu) for your local distributor/importer.

# SMC Corporation

URL : <https://www.smcworld.com> (Global) <https://www.smc.eu> (Europe)  
 SMC Corporation, 4-14-1, Sotokanda, Chiyoda-ku, Tokyo 101-0021, Japan  
 Specifications are subject to change without prior notice from the manufacturer.  
 © SMC Corporation All Rights Reserved.  
 Template DKP50047-F-085N